Operation and Service Instructions

Single Tank MicroBlaster MB1000

Issue Date: May 2002

This manual covers all variations of the MB1000 series manufactured prior to January 1, 2003. These blasting units will have a serial number below 12,100.

(MB1000-1, MB1000-2, ETC)

Comco, Inc.
2151 N. Lincoln Street
Burbank, California 91504
USA

Phone: 818-841-5500
FAX: 818-955-8365
Web Site: www.COMCOinc.com

Book P/N MB1245-1
File: MB1000.doc

Table of Contents

The Comco Warranty	iv
Safety Precautions	v
Section 1: The MicroBlaster MB1000	1-1
<i>This section introduces you to the basic unit, including its description, principles of operation, and detail specifications.</i>	
Overview.....	1-2
Figure 1-1, MicroBlaster MB1000	1-2
How The MicroBlaster Works	1-3
Figure 1-2, MicroBlaster Pressurized	1-3
Figure 1-3, Modulator Open.....	1-4
Figure 1-4, Modulator Closed	1-5
Detail Specifications	1-6
Section 2: Getting Started	2-1
<i>This section tells you what you need to have and what you need to do to set up the MicroBlaster.</i>	
The Proper Work Area	2-2
Figure 2-1, Micro-abrasive Blasting System Requirements.....	2-3
Figure 2-2, MicroBlaster Reference Sheet	2-4
What You Received with the MicroBlaster	2-5
Basic Components of the MicroBlaster	2-6
Figure 2-3, External Component Locations	2-7
Setup and Test.....	2-8
Section 3: Using the MicroBlaster	3-1
<i>This section discusses the selection of key operating parameters such as abrasives and nozzles; and tells you how to operate the MicroBlaster for maximum efficiency.</i>	
Abrasive Selection.....	3-2
Table 3-1, Factors Affecting Abrasive Blasting.....	3-3
Table 3-2, Abrasives and Their Applications	3-5
Tank Orifice and Nozzle Selection	3-6
Table 3-3, Orifice Selection Chart.....	3-7
Figure 3-1, Changing the Tank Orifice.....	3-7
Figure 3-2, Changing the Nozzle	3-8
Table 3-4, Nozzle Chart.....	3-9
General Operation of the MicroBlaster	3-12
Figure 3-3, Filling the Abrasive Tank.....	3-13
Figure 3-4, Controls and Indicators	3-14

Table of Contents

Section 4: Maintenance	4-1
<i>This section tells you what you need to do to keep the MicroBlaster operating properly.</i>	
Normal Maintenance	4-2
Table 4-1, Maintenance Intervals	4-3
Parts Subject to Normal Wear	4-4
Figure 4-1, Pinch Tube and Plunger Inspection	4-5
Figure 4-2, Instructions for Testing Tank Cover Threads	4-7
Leaks	4-8
Moisture	4-8
Auxiliary Equipment	4-9
Section 5: Trouble-shooting and Repair	5-1
<i>This section tells you what to do if you have a problem with the MicroBlaster.</i>	
Trouble-shooting	5-2
Customer Service	5-2
How to Order Replacement Parts	5-3
Common Problems, Causes, and Solutions	5-4
Table 5-1, No Air Flow	5-4
Table 5-2, No Abrasive Flow	5-5
Replacing the Abrasive Hose and Fittings	5-6
Inspecting and Repairing the Pinch Valve	5-8
Inspecting and Repairing the Modulator	5-10
Figure 5-1, Modulator Assembly	5-11
Clogging	5-13
Air Pressure Regulator	5-14
Tank Cover	5-15
Appendices	
<i>This section presents parts lists, drawings and schematics for the MicroBlaster MB1000 and WorkStations.</i>	
Appendix A: Parts Lists	A-1
Major Assemblies and Principal Parts	A-2
Standard Accessory Parts	A-6
Optional Parts	A-7
Recommended Spares	A-8
Appendix B: Drawings and Schematics	B-1
Appendix C: WorkStations	C-1

Welcome!

Welcome to the User's Manual for the Comco MicroBlaster model MB1000 Micro-abrasive Blaster! You have purchased the finest micro-abrasive blaster available today, and this manual is designed to help you set up, operate, and maintain the MicroBlaster MB1000.

NOTE: **Prior to setting up and operating your MicroBlaster, the operator and the department supervisor should carefully review this entire manual.**

The Comco Warranty

Comco warrants that the MicroBlaster MB1000 will be free from all defects in material and workmanship under normal use for a period of one year from the date of purchase or 2,000 hours of normal operation, whichever comes first.

The warranty period begins when the equipment ships from the Comco facility and applies to the original owner only. Comco is not liable for damages from any cause or use of such equipment beyond the cost of repairing any defective parts.

If the equipment fails to perform satisfactorily during the warranty period, Comco has the option to do any one of the following: 1) Send replacement parts to the customer to be installed by the customer; 2) Repair the unit at the customer's facility; or 3) Request that the unit be returned to the Comco factory. Any replacement parts shall be furnished by Comco without cost, F.O.B. the Comco factory in Burbank, California, provided that Comco is notified of the defect within the warranty period. Any defective parts shall be returned to Comco for inspection and analysis.

Exclusions

The above warranty does not apply to defects or problems resulting from improper or inadequate maintenance by the customer; unauthorized modification or misuse; failure to follow the operating instructions; the use of any supplies or parts, including but not limited to nozzles, powders, and attachments, not manufactured or supplied by Comco.

The warranty also does not cover problems resulting from improper or inadequate facilities (contaminated air, improper power) or items that should be expected to wear in normal operation, such as nozzles, abrasives, tubing, or fittings.

This is Comco's only warranty and is in lieu of all other warranties of merchantability and fitness for any particular purpose. No representations or warranties are authorized except as herein stated.

Safety Precautions

General Safety Considerations

The MicroBlaster has been designed to be safe to operate when used properly. Any device that is pressurized and requires electrical power, however, requires that certain safety precautions be observed to avoid potentially hazardous situations. The primary safety-related issues involved in the use of the MicroBlaster are listed below; and addressed in detail on the following pages.

1. Working with a device that is pressurized.
2. Working with an electrical device.
3. Working with a device that uses abrasive powders that could be potentially dangerous if inhaled or ingested in large quantities or put in constant contact with the skin.
4. General issues involved in operating machinery.

Working with a Device that is Pressurized

The MicroBlaster uses pressurized air to perform its basic function. While Comco's blasting machines incorporate relief valves and check valves to minimize the risk of an accident related to air pressure, Comco also recommends the following:

- ✓ The air supply system should have a shutoff valve located upstream of the blasting machine so that the supply pressure can be turned off independently of the blaster.
- ✓ Pressure relief valves should be incorporated into the supply system to minimize the risk from system over pressure.
- ✓ Anyone who will use the MB1000 should be trained in its basic operation.
- ✓ The MicroBlaster should always be turned OFF and vented prior to performing any maintenance.
- ✓ When replacing parts during maintenance, use only Comco parts and verify that all installations are correct before using the MicroBlaster.
- ✓ Use the Tank Lid Thread Gage on a regular basis to ensure Tank Lid Safety.

Improper set-up or use of the MicroBlaster MB1000 may result in a condition that could be hazardous. All fittings and covers must be properly installed and tightened in order to minimize any hazard.

Working with an Electrical Device

The electrical hazards associated with the MicroBlaster are minimal, since all primary electrical components are inside the primary housing. However, the operator should take precautions that apply to any electrical device that has a power cord that plugs into an electrical outlet. These precautions include:

- ✓ Verify the proper operating voltage on the MicroBlaster by checking the nameplate located on the back of the unit.
- ✓ Before plugging the power cord into an electrical outlet, examine it for evidence of damage such as cracked, worn, or torn insulation; exposure of bare wires; or bent tines on the plug.
- ✓ Ensure that the machine is never operated near water or while it is wet.
- ✓ Always verify that the power switch is in the OFF position when the machine is not in use for long periods of time.

When working inside the MicroBlaster housing, there is the possibility of electrical shock. To minimize this hazard, Comco recommends the following:

- ✓ Unplug the unit from facility power any time the machine's cover will be removed.
- ✓ Do not operate the MicroBlaster with its cover removed.
- ✓ Keep the interior of the MicroBlaster clean of dust, powder, and any foreign object or substance that could conduct electricity.

<p>CAUTION: Some abrasive powders are conductive and may present a hazard if allowed to accumulate inside the machine.</p>

Working with the Abrasive Media

The MicroBlaster uses several types of abrasive media that should not be inhaled or ingested in large quantities or maintained in prolonged contact with the skin. When working with the abrasive media, Comco recommends the following:

- ✓ Do not direct the abrasive blast on bare skin or face/eyes.
- ✓ A WorkStation and dust collector **must** be used in conjunction with the MicroBlaster. If you must blast outside a WorkStation, a full face mask and oxygen supplied respirator and hand protection are required per NIOSH (National Institute for Occupational Safety and Health).
- ✓ Handling operations such as repackaging or refilling of the abrasive media should only be performed in well-ventilated areas and with proper care to minimize dust in the eyes or breathing passages. Always use a dust respirator for dust protection when exposed to dust clouds. The 3M respirator #8710 is NIOSH/MSHA approved for these types of abrasive handling operations.

Working with the Abrasive Media (cont'd)

- ✓ Certain abrasive media, such as glass beads, can present a slipping hazard if they are spilled on the ground. Always clean up spilled abrasive and place appropriate warning signs in areas where the abrasive will be on the ground (such as during long-term operation).
- ✓ Abrasive powders, particularly glass beads and plastic, may generate static charges. To minimize the risk of electrostatic discharge, ground the MicroBlaster and the WorkStation. In some instances, the operator may also wish to use grounding straps (Wrist-Stats™ or equivalent).
- ✓ Flammable powders, such as walnut shell and plastic, may pose a fire or explosion hazard. Always use a vigorous dust extraction device to prevent hanging dust clouds.
- ✓ After using the MicroBlaster, or after handling any of the abrasive media, wash your hands before touching or rubbing your eyes.
- ✓ Gloves may be necessary for operators who are sensitive to powders or dust on their skin.
- ✓ Some powders, if allowed to collect inside the machine, may cause electrical shorts.
- ✓ Abrasives cause wear to virtually every surface they come in contact with. Keep the threads on the tank and tank cover clean of abrasive powder to avoid wear that can cause a dangerous condition. See Section 4 for details on how to check for tank cover wear. Also, always fill the tank through the flapper valve to greatly reduce the amount of wear on the threads.

Material safety data sheets (MSDS's) for all abrasives distributed by Comco are available from the Comco factory. Every powder shipment includes an MSDS. Contact the Comco Customer Service department to obtain extra copies of any MSDS.

Avoiding Hazards Associated with Operating Machinery

- ✓ Place the MicroBlaster securely on a solid workbench or counter so that the unit cannot tilt or fall over.
- ✓ Always secure the nozzle-end of the abrasive blast hose before pressurizing a blasting unit. An unsecured hose may whip around and cause injury or damage.
- ✓ Keep fingers out of the hose pinch.
- ✓ When working inside the cabinet, avoid possible sharp edges and remember that solenoids on valves can become hot.
- ✓ Set up the MicroBlaster and WorkStation so that it is ergonomically correct to allow safe and comfortable use by all operators.
- ✓ Route the foot pedal cord from behind the bench to prevent it from becoming a possible trip hazard.
- ✓ When refilling the tank, set the tank cover flat on its end to avoid it rolling off the bench.

Avoiding Hazards Associated with Operating Machinery (cont'd)

The following warning labels/pictograms are utilized in the MicroBlaster CE (European) versions:

Symbol	Meaning
	ELECTRICAL HAZARD
	HAND PROTECTION RECOMMENDED WHERE APPROPRIATE
	EYE PROTECTION RECOMMENDED WHERE APPROPRIATE
	RESPIRATORY PROTECTION RECOMMENDED WHERE APPROPRIATE

Section 1: The MicroBlaster MB1000

In This Section

This section gives you an overview of your MicroBlaster including:

- ◆ A general description of the MicroBlaster.
- ◆ How the MicroBlaster Works.
- ◆ Detail specifications.

Overview

The Comco MicroBlaster Model MB1000 is a compact bench-top machine that delivers a precisely controlled stream of micro-abrasive particles at high velocity. With the appropriate abrasive powder and the necessary adjustments, it will clean, deburr, cut or drill any material, particularly hard or brittle ones. Since dry air is used as a propellant, it is a relatively clean process.

The machine is essentially simple and uncluttered (see Figure 1-1). It consists principally of an inlet air valve (rear panel), air pressure regulator with gage, modulator (internal), abrasive powder tank, and mixing chamber. The abrasive hose pinch assembly to stop and start the abrasive flow, the footswitch to actuate it, and a handpiece that holds the precision nozzle, complete the machine. All the component parts are manufactured to the highest standards and are designed for maximum life consistent with reasonable cost. The basic mechanisms employed, particularly the modulator, are covered by the following patents:

United States:3,053,016 Johnson
 3,084,484 Hall
 3,638,839 Weightman
 United Kingdom:1,243,294

Additional United States and foreign applications for patents are pending.

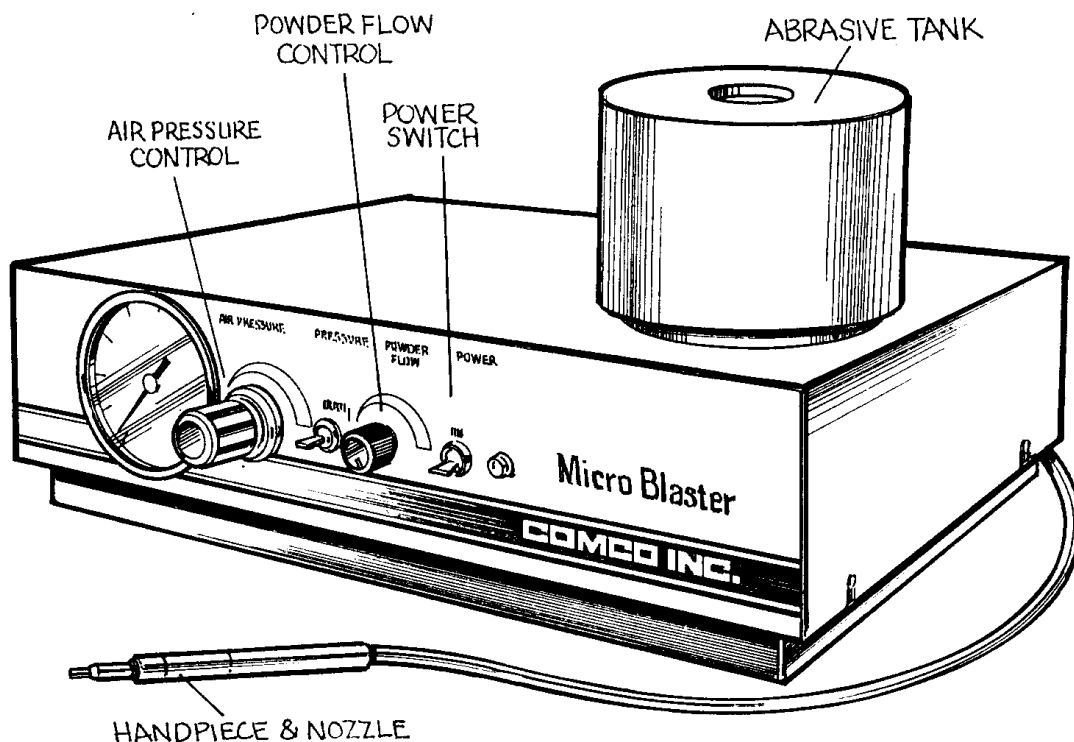

Figure 1-1: The Comco Single Tank MicroBlaster MB1000

How the MicroBlaster Works

As shown in Figure 1-2, below, when the MicroBlaster Power Switch on the front panel is initially turned "ON", supply air enters through the energized air valve at the back of the unit. The supply air passes through a regulator that allows the operator to control the system pressure, as indicated by the gage on the front of the machine.

The regulated air then passes through an open, or de-energized, modulator assembly and into the mixing chamber and abrasive tank. Air cannot escape through the nozzle because the hose pinch (or shut-off) assembly is closed. The air pressure inside the system builds up until it reaches the regulated pressure.

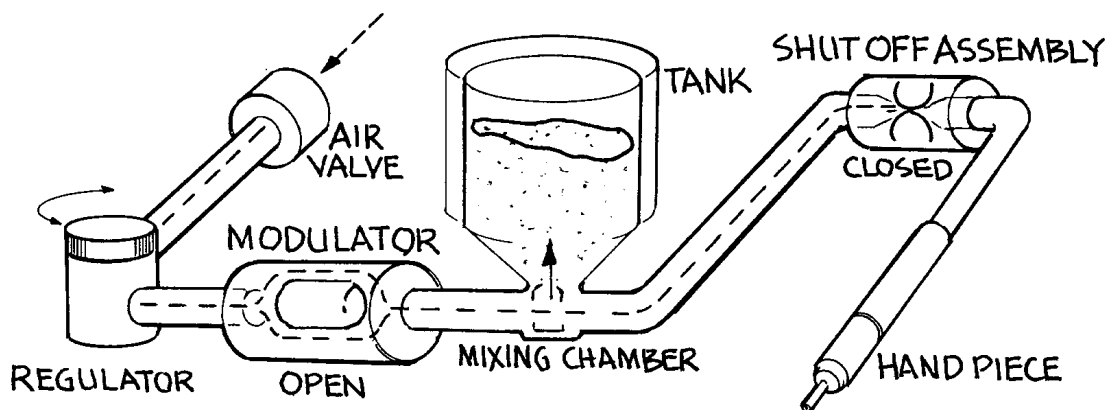

Figure 1-2: MicroBlaster, Pressurized

The MicroBlaster, as shown in the illustration above, is now pressurized and ready to use. To operate the MicroBlaster from this point would simply require picking up the nozzle, pointing it at the item to be blasted, and depressing the footswitch to begin blasting. What happens when the machine is actually in operation is explained on the following pages.

How the MicroBlaster MB1000 Works (cont'd)

Stepping on the footswitch used to operate the MicroBlaster causes two things to happen:

- 1) The hose pinch (shut-off) assembly opens, which allows air to flow from the nozzle. Refer to Figure 1-3, item 1.
- 2) An electrical signal is sent to the coil of the modulator assembly which energizes and de-energizes it 60 times every second. Refer to Figure 1-4, item 2.

At the beginning of the operating cycle (as shown in Figure 1-3, below), the hose pinch is opened. Before the modulator has had a chance to energize, regulated air flows freely through the open modulator valve, the mixing chamber, and out the nozzle.

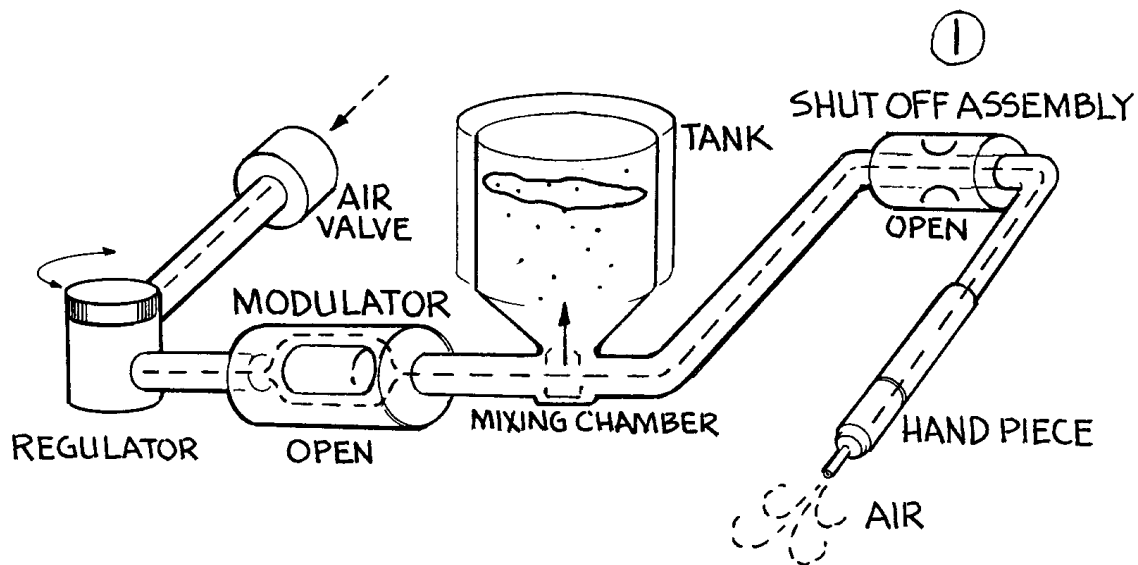

Figure 1-3: Modulator Open

Since the air flowing from the regulator into the mixing chamber is at basically the same pressure as that in the tank, the upward force of air keeps the abrasive in the tank. At this point, little or no abrasive is being injected into the air stream.

How the MicroBlaster MB1000 Works (cont'd)

In the second half of the operating cycle, the modulator coil becomes energized. This pulls the modulator core against the seat (see Figure 1-4, below), shutting off the airflow from the regulator. The pressure in the mixing chamber now decreases because the downstream end of the system, at the nozzle, is open to the atmosphere.

Since the pressure in the mixing chamber is lower than the pressure in the abrasive tank, the two pressures try to balance. Air pressure inside the abrasive tank pushes a small amount of abrasive through a precision orifice at the bottom of the tank, into the mixing chamber and out through the nozzle.

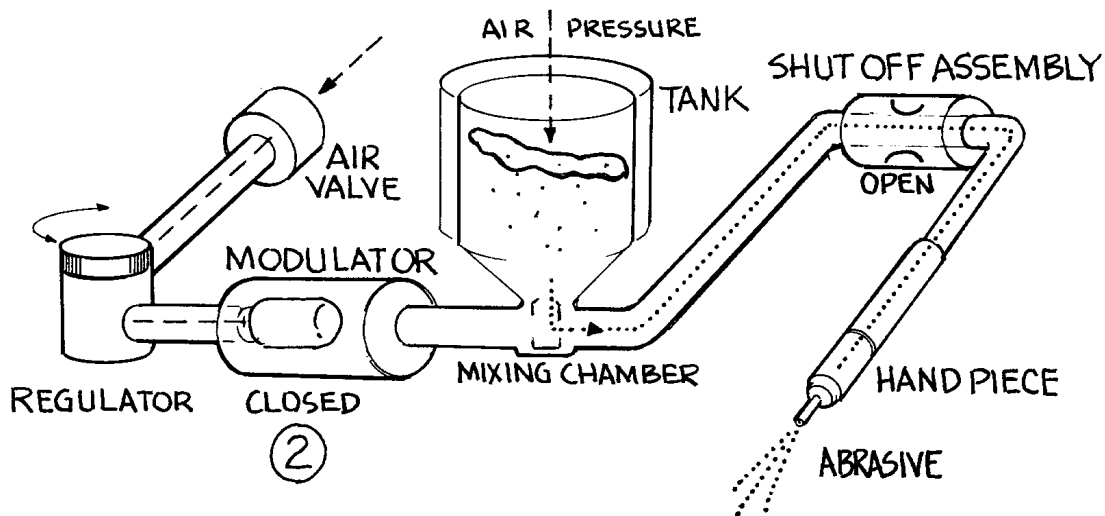

Figure 1-4: Modulator Closed

When the next cycle begins, the modulator is again de-energized, and opens to allow pressurized air to freely flow into the mixing chamber and out the nozzle. This forces air back into the abrasive tank, stabilizing the pressure between the tank and the mixing chamber (refer back to Figure 1-3).

Each cycle happens very quickly; 50-60 times per second. The end result of this "stop/start" action of the modulator is a consistent stream of abrasive out the nozzle, as long as the footswitch is depressed. Releasing the footswitch stops the modulator from cycling and causes the pinch assembly to close the outlet air hose.

The only way for the abrasive powder in the tank to reach the mixing chamber is via the orifice at the bottom of the tank. By changing the size of the tank orifice, you can change the amount of abrasive that enters the mixing chamber, and thus change the abrasion or cutting rate at the nozzle. Additional information regarding the tank orifice, nozzle sizes, abrasives, and other variables in the abrasive blast process is presented in Section 3 of this manual.

Detail Specifications

Abrasive (see Section 3)

Type	Selected powder, smooth to sharp, soft to hard
Size	20 to 300 Microns

Nozzles (see Section 3)

Material	Highest quality Tungsten Carbide
Sizes, Round	0.015 to 0.060 in. Dia. (.381 to 1.524 mm)
Sizes, Rect.	0.008 x 0.020 to 0.012 x 0.150 in. (.203 x .508 to .305 x 3.81 mm)
Configuration	Straight or Right Angle

Air

Type	Dry Compressed Air, Nitrogen, or CO ₂
Supply Pressure	80 to 140 PSIG (5.5 to 9.65 Bars)
Volume, Max	2.4 SCFM (68 SLM)
Working Pressure	40 to 125 PSI (2.7 to 8.6 Bars)
Moisture	200 PPM Max
Oil	10 PPM Max
Particles	5 Microns Max

Electrical

Voltage ^[1]	115 or 230 (+10, -20) VAC
Frequency	50/60 Hz
Power	40 Watts

Physical

Width	16.5 in. (42 cm)
Depth	10 in. (25.5 cm)
Height	9 in. (23 cm)
Weight	20.5 lbs. (9.3 kg)
Tank Volume	50 in ³ (820 cm ³)
Tank Capacity, abrasive	2 lbs. (1 kg)

During normal operation, employing a 0.030" diameter nozzle, a 0.025" diameter tank orifice, and 25 micron aluminum oxide powder; a full tank of powder (approximately 2 lbs.) will last about 4 hours of actual blast time; air will be used at about 60 standard cubic feet per hour at 80 psig; and nozzle life will be 8 to 35 hours depending on the amount of wear that can be tolerated.

^[1] Operating voltage specified by order and as shown on nameplate.

Section 2: Getting Started

In This Section

This section tells you what you need to do to prepare for using your MicroBlaster, including:

- ◆ The work area required to properly use the MicroBlaster.
- ◆ What you received with the MicroBlaster.
- ◆ Basic Components of the MicroBlaster.
- ◆ Setting up and testing the MicroBlaster.

The Proper Work Area

The MicroBlaster should be used in an environment that:

- Provides adequate ventilation.
- Provides adequate lighting both inside and outside the primary WorkStation. Comco recommends that the general environment be illuminated with at least 50 decaluxes and that the interior of the WorkStation be illuminated with a minimum of 125 decaluxes.
- Is between 68°F and 85°F, with less than 40 percent relative humidity.

The MicroBlaster is intended for use in a factory or shop environment. It is **not** designed for use where it could be exposed to rain, caustic chemicals, heavy vibration, and other non-standard environments. Use in applications other than those described in this manual may result in hazardous conditions and void the warranty.

Since it is impossible to achieve 100% containment of the abrasive within the system, it is not recommended for use in a “clean room”.

In addition to the MicroBlaster, typically three additional elements are needed for proper micro-abrasive blasting: a WorkStation, a dust collector, and a dry air supply. The following paragraphs explain the importance of each of these items. Refer to figure 2-1 to see how these items work together as a complete system.

WorkStation

A suitable hood or box providing a means of working with the abrasive material without contaminating the atmosphere of the room is required. It must protect the operator's face and provide adequate light. The Comco WS2200 and WS6000 WorkStations are designed for this purpose. Refer to Appendix C for more information.

Dust Collector

In order to remove the spent abrasive, a suitable industrial dust collector is required. These dust collectors have both high airflow and large filter areas to keep work areas clean and dust free. The Comco DC2000 and DC2100 are both suitable dust collectors for most micro-abrasive blasting applications. A four-inch diameter hose, supplied with the dust collector, is used to connect the WorkStation to the dust collector.

Air Supply

The propellant required for the abrasive is compressed air or neutral gas that meets the Detail Specifications outlined in Section 1. Comco has a complete line of air dryers for shop (compressed) air supplies that will meet or exceed those specifications.

Bottled gas such as CO₂ or nitrogen provides clean, dry air, and may be used if shop air is not available. However, depending on operating conditions, a 50 lb. bottle of gas will only last 10-20 hours. Bottled gas does not require air dryers, but may require special regulators. Contact Comco for more information.

Figure 2-1: Micro-abrasive Blasting System Requirements

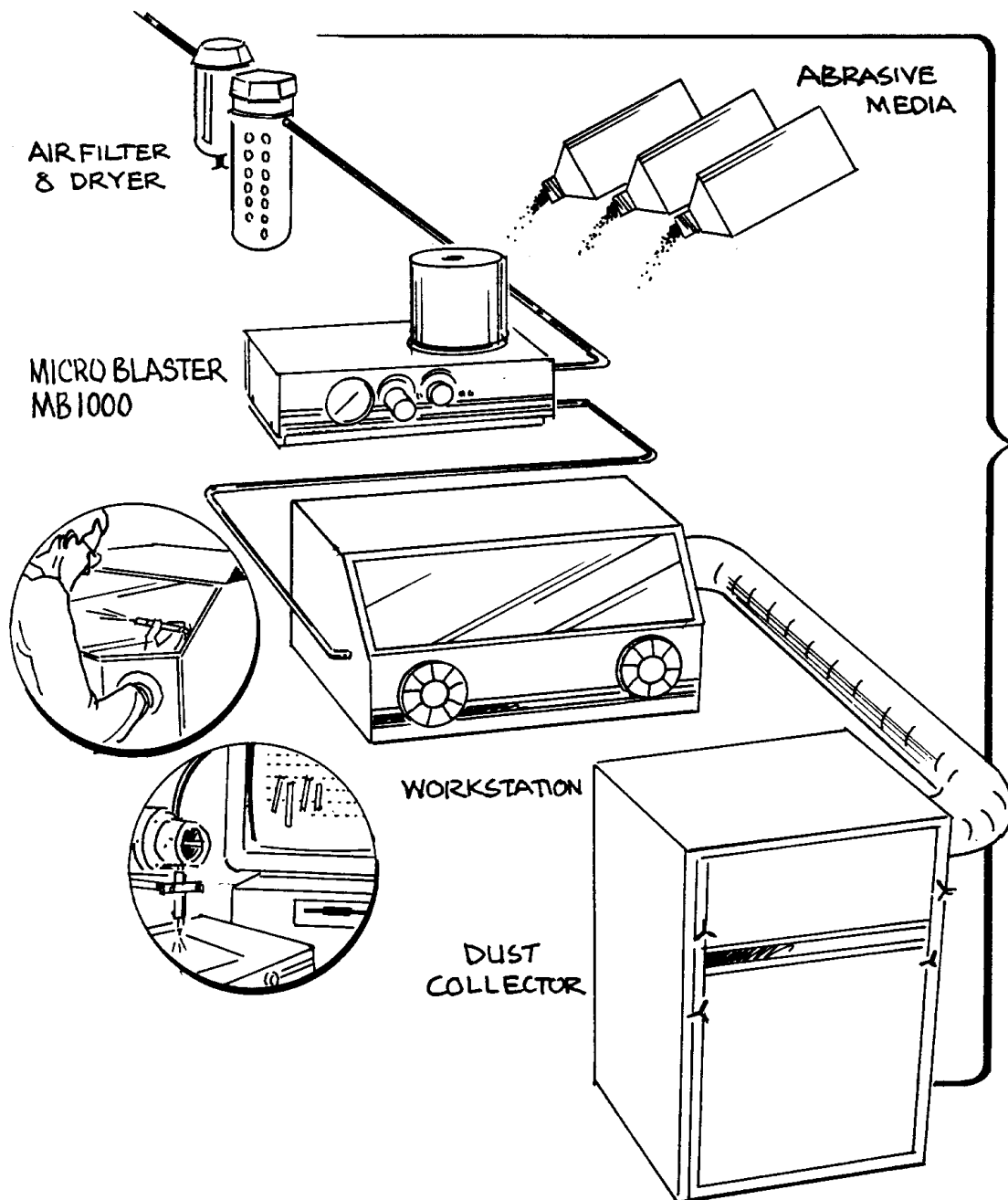

Electric Power

A source of 115 or 230 VAC, 50/60 Hz, capable of providing 100 watts is required for the MB1000. If the WS2200 or WS6000 WorkStation is used, it requires 40 watts. The DC2100 Dust Collector, if used, requires about 16 amps for its 1-HP motor. Actual voltage required for each machine will be found on the nameplate.

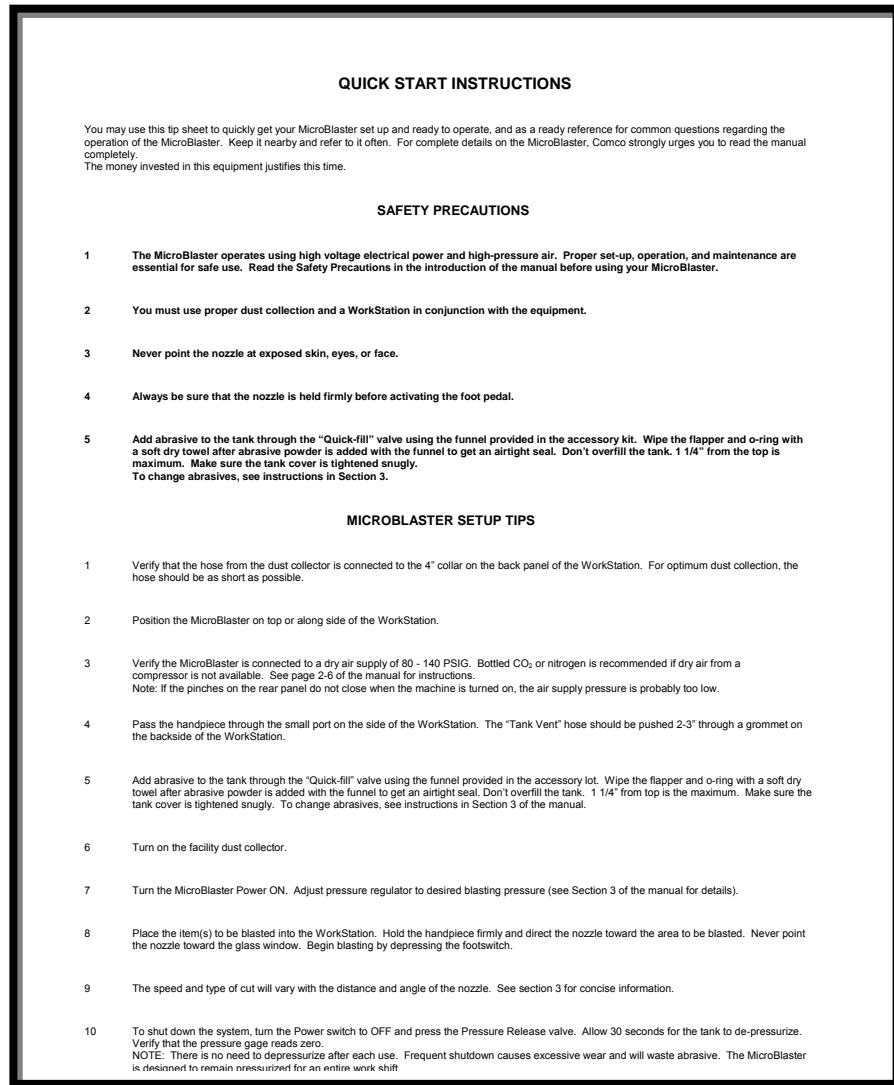

Figure 2-2: MicroBlaster Reference Sheet

Figure 2-2 is an illustration of the Reference Sheet that comes with your MicroBlaster. It contains important information you can use to get the most out of your investment. Keep it nearby and refer to it often. However, it cannot substitute for the comprehensive data found in this manual. Prior to setting up and operating your MicroBlaster, the operator and the department supervisor should carefully review this entire manual.

What You Received With Your MicroBlaster

CAUTION: The shipping carton containing the MB1000 and accessories weighs approximately 35 pounds. Use appropriate caution while lifting.

The MicroBlaster MB1000 is shipped fully assembled and requires only minimal set-up to use. The following pages describe what is needed, and how to set up and test your micro-abrasive blasting system for proper operation.

Once you receive your MicroBlaster MB1000, check the contents of the shipping carton to make sure that you have received all of the items. Besides this manual and the Reference Sheet pictured on the previous page, you should find the standard Accessory Parts Kit as listed below. Note that two additional items, a .025" tank orifice, MB1409-25, and a .030" nozzle, MB1500-11 (green), should already be installed on the MicroBlaster MB1000.

Open all small packages within the large carton carefully, since many small parts are included with the shipment.

STANDARD ACCESSORY PARTS, MB1089-11 ^[1]

<u>PART NUMBER</u>	<u>DESCRIPTION</u>	<u>QTY.</u>
MB1500-22	Nozzle, .008 x .125, Olive	1
MB1500-24	Nozzle, .018, Violet	1
MB1500-29	Nozzle, .046, Yellow	1
MB1409-40	Orifice, Tank, .040	1
MB1021	Orifice, Bypass	1
MB1233	Tube, Abrasive, Poly	6 ft
MB1435	Gage, Thread	1
ST4005	Bushing, .250T x .125P, Brs	1
ST4006	Connector, 1/4T x 1/8P	1
ST4012	Tube, Plastic, 1/4	6 ft
ST5066	Funnel, Abrasive	1
ST7625-010 *	Fuse, 1 Amp	2
PD1003-4	Abrasive, C, 50 micron, Alum Oxide	1 Btl.
PD1004-3	Abrasive, D, 50 micron, Glass Bead	1 Btl.

^[1] The kit for 230V machines is MB1089-15; the Fuse is ST7625-005. A Nut Driver, ST5114, is added to the kit.

Basic Components of the MicroBlaster MB1000

Power Switch

The Power Switch is located on the right-hand side of the unit. It is the primary ON/OFF switch for the unit. The Power Indicator will illuminate when the power is "ON".

Pressure Release Valve

The Pressure Release Valve is located in the center of the front panel. It is used to vent the pressure in the MicroBlaster, once power is turned off. You may push the switch either up or down to vent the pressure. You should only have to hold this switch for a few seconds for it to operate. **NOTE:** Only press the Pressure Release lever when the Power is "OFF".

Handpiece

The handpiece, which holds the blasting nozzle, should be inserted into the holes in the side of the WorkStation provided for this purpose.

Air Pressure Regulator

The Air Pressure Regulator knob on the front of the unit controls the MicroBlaster's operating air pressure as indicated on the pressure gage located directly to the left of it. To adjust the pressure, rotate it clockwise to increase the pressure or counterclockwise to decrease the pressure. **NOTE:** The pressure will not decrease until the foot switch is depressed.

Pressure Gage

The Pressure Gage on the front of the unit indicates the air pressure in the abrasive tank. Typically, operating pressure selected for the process will be between 30 psig and 125 psig.

Powder Flow Control (Not applicable to older models)

The Powder Flow Control knob controls the amount of clean, abrasive-free air that is mixed with the abrasive in the mixing chamber. Turning the knob clockwise increases the concentration of media in the air stream.

Footswitch

The Footswitch (usually placed on the floor) activates the abrasive hose pinch and the modulator, allowing abrasive to flow from the tank to the blasting nozzle.

"Quick-Fill" or Flapper Valve

The Flapper Valve is located on the top of the tank cover. It is used to fill the tank with abrasive powder. **NOTE:** Only refill the abrasive tank after MicroBlaster Power has been turned "OFF" and unit has been vented.

Pinch

The Pinch assemblies are located on the rear panel of the MicroBlaster. The pinch squeezes the blue poly hose in order to stop the flow of air and abrasive.

Figure 2-3: External Component Locations

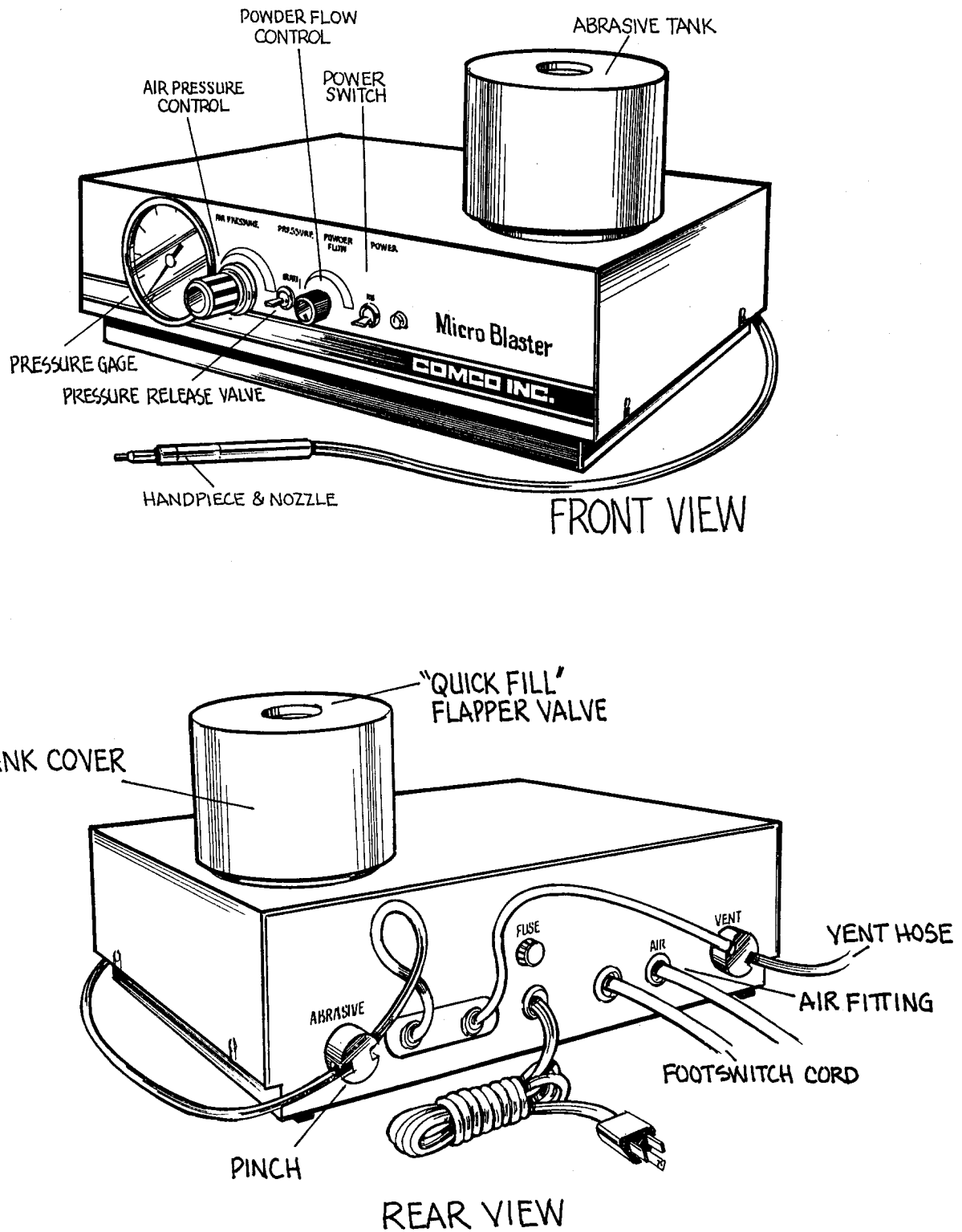

Set-Up and Test

1. Place the MicroBlaster in the area it will normally occupy, within reach of the electrical outlet and the air source. Generally, this will be on top of or alongside the WorkStation.

CAUTION:

The MB1000 weighs approx. 21 pounds. Use appropriate caution while lifting.

2. Remove the tank cover by twisting counterclockwise. Carefully clean out any foreign material. Replace the tank cover and tighten firmly, by hand.
3. Connect the MicroBlaster to a dry air supply.
 - a. At the rear panel of the MicroBlaster, locate the push-in "Air" fitting. Refer to Figure 2-3.
 - b. Insert one end of the white tubing (ST4012), supplied in the accessory parts kit, into the fitting. Push the tube all the way into the fitting until it stops. Check for proper connection by attempting to pull the hose out of the fitting. Note: To disconnect hose from fitting, push the hose collar in while pulling hose out.
 - c. Connect the other end of the air tubing (may be cut to length) to the gas or air supply. Additional tube or pipe fittings may be required in some instances and are available from the factory.
4. Set the pressure of the air supply at the high pressure supply regulator or dryer cabinet to at least 80 PSI but not more than 140 PSI.
5. Plug the power cord into a 115 or 230 VAC outlet.

CAUTION:

The MicroBlaster can be manufactured for either 115VAC or 230VAC. Check the voltage on the nameplate located on the back panel to see which voltage is correct for your machine.

6. Place the footswitch in any convenient position for the operator.
7. Place the end of the hose connected to the "Tank Vent" on the rear of the machine into one of the grommets on the back of the WorkStation. With the 4" dust collector hose removed from the back of the WorkStation, reach into the 4" duct and pull several inches of the blue hose into the back of the WorkStation.

CAUTION:

The air that comes out of the vent hose will contain abrasive. Place the free end of the vent hose into the WorkStation or the dust collector. **Always** secure the free end of the hose.

Set-Up and Test (cont'd)

8. Pass the handpiece through the small port on the side of the WorkStation.
9. Turn the "Power" Switch to "ON". The system should start to pressurize with an audible hissing sound (approximately 5 seconds). Listen for obvious leaks.

CAUTION:

Do not lean over the abrasive tank while the system is pressurizing.

10. Adjust the pressure with the "Air Pressure" regulator knob (Figure 2-3) until the needle on the pressure gage is centered at 80 PSI. Turning the knob clockwise raises the pressure. Turning it counterclockwise lowers pressure, although the gage will not show a drop until the next step, when the footswitch is depressed.
11. Firmly hold the nozzle inside the WorkStation or hood, and step on the footswitch. Air should immediately escape from the nozzle. It should stop when the foot is lifted. Be sure the nozzle is pointed away from the glass window.

CAUTION:

The air that comes out of the nozzle contains abrasive. Do not point the nozzle at anything that could be harmed or damaged as a result of abrasive flow, especially the WorkStation glass window.

12. Step on the footswitch again. As air escapes from the nozzle, the modulator will hum audibly, indicating that it is working properly.
13. Turn the "Power" Switch to "OFF".
14. Listen carefully for any obvious air leaks. Watch the needle on the pressure gage. It should remain steady or fall very slowly.
15. Press the "Pressure Release" toggle lever down and hold for three to five seconds. Air will escape through the front of the valve until the pressure in the vent pinch cylinders is lowered sufficiently to allow the cylinders to open. The remainder of the air in the powder tank will then escape through the vent hose (connected to the WorkStation in Step 7).
16. You are now ready to select the proper abrasive, nozzle and other operational parameters to begin using your MicroBlaster. These issues, as well as detailed operational instructions, are discussed in the next section.

Section 3: Using the MicroBlaster

In This Section

This section tells you what how to efficiently operate your MicroBlaster, including:

- ◆ Abrasive selection.
- ◆ Orifice and Nozzle selection.
- ◆ General operation of the MicroBlaster.

The Essence of Micro-Abrasive Blasting

There are many variables that affect the results you will get from the micro-abrasive blasting process. In order to get the most from your MicroBlaster, a thorough understanding of these factors is essential.

The single most important factor in getting the maximum benefit from your MicroBlaster is in proper abrasive selection. With the right abrasive, you can lightly clean soft materials, or deburr machined metal parts.

Once the correct abrasive is chosen, the remaining factors that affect the abrasive actions are: the number of particles striking the work area, the velocity of the particles, and the angle of the blast. These factors are controlled by the MicroBlaster through the following conditions:

- Tank Orifice Size
- Nozzle Size
- Nozzle to Work Distance
- Angle of Nozzle to Work Surface
- Air Pressure
- Powder Flow Adjustment Setting*
- Bypass orifice

Table 3-1 gives a brief overview of all of these essential factors. Each of them is discussed in detail on the following pages, beginning with abrasive selection.

* Not applicable to older models.

**Table 3-1: General Summary
of Factors Affecting Abrasive Blasting**

Variable	Comments	Manual Reference
The Abrasive	The abrasive you use has the most significant impact on how well the unit works. Hardness, sharpness, and particle size all affect cutting speed. In general, the larger the particle size, the faster the cutting or abrading will be.	See the information under the Abrasive Selection heading within this section.
The Tank Orifice	Other factors being equal, the amount of powder flow is directly proportional to the size of the powder orifice. The orifice should be sized according to the abrasive used, so that a small orifice is not used with large particles.	See the Tank Orifice discussion within this section.
The Nozzle	Nozzles with larger openings produce larger blast patterns, thus speeding up some blast processes.	See the Nozzle Size discussion within this section.
The Air Pressure	The higher the pressure, the faster the work will be abraded. Nozzles, hoses, and fittings also wear out faster with higher pressures.	See the Air Pressure heading within this section.
The Distance between the nozzle and the work	Up to a point, the closer the nozzle gets to the work the faster the material will be removed beneath the nozzle. A distance of about 5-8 times the nozzle diameter will generally remove the maximum material.	See the Nozzle Distance discussion within this section.
The Angle of the abrasive stream to the work	Cutting rate will improve as the nozzle is tipped at an angle relative to the surface of the material. Tipping the nozzle also tends to work better for cleaning a surface.	See the Angle of Approach heading within this section.
The Powder Flow Adjustment*	Fine adjustments in the amount of powder in the air stream can be made with the powder flow control knob on the front panel. Less powder and more air tends to cut faster at close nozzle distances.	See the Powder Flow Adjustment heading within this section.
The Bypass Orifice	This is an optional device inserted into the abrasive tank bypass tube that may be used to increase abrasive flow, ultimately resulting in faster cutting action.	See the Bypass Orifice heading within this section.

* Not applicable to older models.

Abrasive Selection

An abrasive material has three characteristics that affect its cutting action: hardness, sharpness (shape), and particle size. The most common abrasive materials are listed below.

<u>Material</u>	<u>Hardness</u>	<u>Shape</u>
Sodium Bicarbonate	Soft	Needle
Walnut Shell	Soft	Irregular
Plastic	Moderate	Block
Glass Bead	Hard	Sphere
Crushed Glass	Hard	Irregular
Aluminum Oxide	Very Hard	Block
Silicon Carbide	Extremely Hard	Block

The shape of individual particles of an abrasive material gives a good indication of its cutting action. A spherical particle like a glass bead has virtually no cutting ability, while a “blocky” shaped particle has points and edges that will cut and strip away surface material on impact.

In conjunction with the basic shape of the abrasive particle, the hardness of the particle must also be considered. For example, an irregular shaped particle such as crushed glass may have sharper edges than a blocky particle like aluminum oxide, and would typically cut most materials faster. However, since aluminum oxide is a much harder substance, it will cut through hard materials with much more efficiency, since it is less likely to shatter on impact.

Particle Size

Choosing the abrasive material defines both hardness and sharpness, so the only variable remaining is size. Many different sizes of abrasive media are available for use with the MicroBlaster (see Table 3-2). Particle sizes between 10 and 300 microns (800 - 75 grit) work best. Since the very small orifices in the MicroBlaster may be easily clogged by oversized particles, it is very important that only those materials that have been approved be used and only as directed. Extreme care should be taken that foreign material is not allowed to fall into the powder. **Never try to salvage spent abrasive.**

Typically, the larger the abrasive particle size, the faster the cutting. The MicroBlaster propels the abrasive at a velocity approaching 500 feet per second. At this speed, the increased mass of a larger particle will deliver a considerably larger impact to the work surface. Also, coarser abrasives flow more freely than the finer ones, since they are less likely to be affected by moisture from the atmosphere. Moisture is the biggest problem you will face when working with abrasives, since moisture causes the fine abrasive particles to stick together and “clump up”, preventing a free flow from the tank. Problems associated with moisture in the abrasive powder are discussed in detail in Section 4.

Table 3-2: Common Abrasives and Their Applications

Comco Type	Abrasive Material	Particle Size			Description/Characteristics
		Average Particle Size		Range (Microns)	
		Micron	Inch		
A	Aluminum Oxide	10	0.0004	5 - 25	The most common abrasive used. A very hard abrasive that cuts well through almost any material, particularly brittle ones. Normally leaves a matte finish, with the surface roughness being dependent upon the abrasive size and the blast pressure. Somewhat sensitive to moisture.
J	Aluminum Oxide	17.5	0.0007	10 - 25	
B	Aluminum Oxide	25	0.001	15 - 35	
C	Aluminum Oxide	50	0.002	30 - 80	
N	Aluminum Oxide	150	0.006	75 - 200	
D	Glass Beads	50	0.002	40 - 80	Good for light deburring and satin finishing of some metals but not good for cutting. Can be used to remove loose surface particles such as oxides. Sensitive to moisture.
E	Silicon Carbide	20	0.0008	10 - 40	The fastest cutting of the standard abrasives. The best abrasive to deburr stainless steel and titanium parts. Does not absorb moisture. Dark gray or black in color.
F	Silicon Carbide	50	0.002	30 - 80	
G	Sodium Bicarbonate	50	0.002	20 - 150	A very gentle abrasive, good for very light cutting of soft materials. Can be used to remove conformal coating from PCBs. Water soluble and easily removed from delicate parts. Susceptible to moisture and cannot be heated to above +150°F.
H	Walnut Shell	250	0.010	80 - 300	Gentle abrasive that can clean metal or ceramic surfaces without changing the surface finish. Absorbs moisture easily.
M	Plastic	200	0.008	150 - 300	Good for stripping soft materials, such as paint or conformal coating, from harder substrates.
K	Crushed Glass	80	0.003	40 - 90	For light cutting of soft to medium materials.

NOTE: Always start the work shift with fresh abrasive powder. Powder left sitting in an unpressurized machine overnight can absorb moisture. This contaminated powder can cause flow problems. Keep powder containers sealed and stored in a cool, dry place.

Tank Orifice

The powder tank is fitted with a single orifice at the bottom through which all powder must pass (see Figure 3-1). The amount of powder flowing is directly proportional to the size of this opening.

As seen in the table below, a small increase in the diameter of the tank orifice results in a large increase in the area of the opening. In other words, increasing the tank orifice by only a few thousandths of an inch, can almost double the amount of powder that will pass through it and out the nozzle. This is a very important factor, since the number of abrasive particles striking the work surface has a direct relation to the speed of the cutting action.

Diameter, in.	Area, in ² .	Comco P/N
0.018	2.5×10^{-4}	MB1409-18
0.025	4.9×10^{-4}	MB1409-25
0.030	7.1×10^{-4}	MB1409-30
0.040	12.6×10^{-4}	MB1409-40
0.046	16.6×10^{-4}	MB1409-46

Some judgment is required in selecting an orifice. A very small orifice should not be used with powders of large particle size. Likewise, a very large orifice may cause a small nozzle to plug from excessive powder in the line. See Table 3-3 for guidelines in selecting orifice size.

The MB1000, as shipped from the factory, is equipped with the 0.025" diameter orifice (MB1409-25). Additional orifices are provided in the accessory parts kit. The orifice will have a number stamped on the side that corresponds to the dash number, and opening size. Refer to the table above to determine the size. The tank orifice should be installed finger tight only with a 1/4" nut driver (see Figure 3-1).

For improved performance and longer life, all Comco orifices are carbide lined.

Table 3-3: Orifice Selection Chart

Abrasive Particle Size			Recommended Tank Orifice
Average Particle		Range (Microns)	
Micron	Inch		
10	0.0004	5 - 30	0.025
20	0.0008	10 - 40	0.025
25	0.001	15 - 45	0.025
50	0.002	30 - 80	0.025
150	0.006	65 - 200	0.030
200	0.008	80 - 300	0.040
250	0.010	150 - 300	0.040

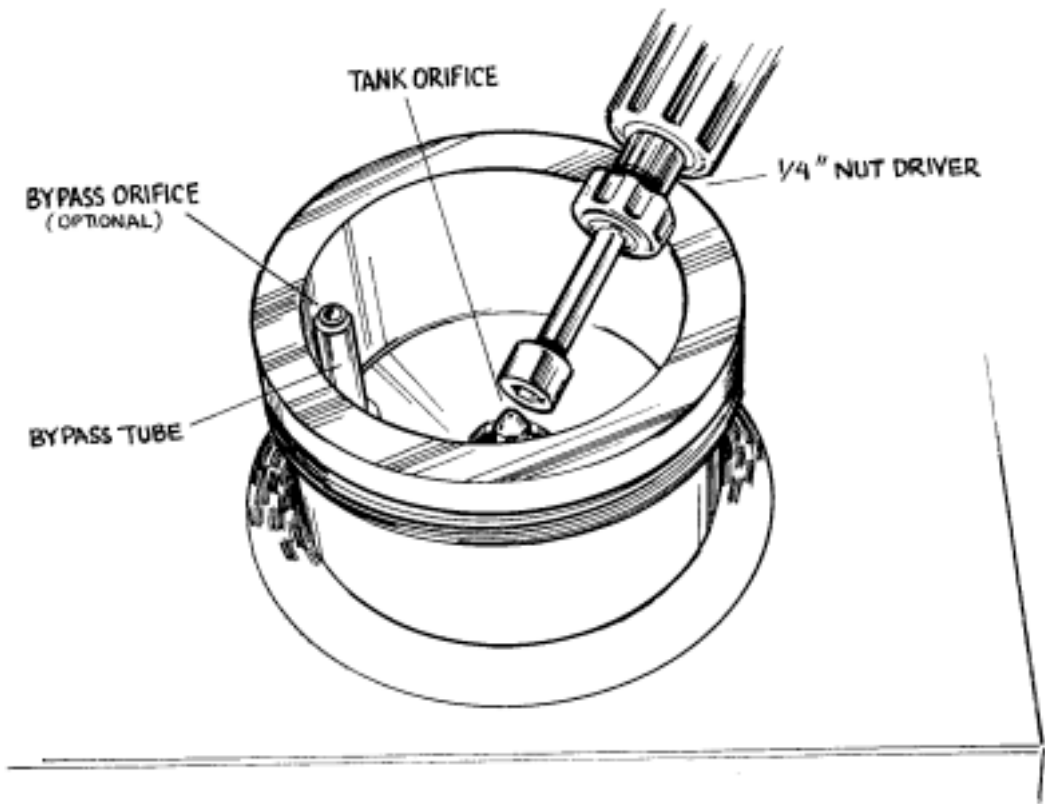

Figure 3-1: Changing the Tank Orifice

Nozzle Size

The type of work to be done usually dictates the type of nozzle that must be used with the MicroBlaster. A very tiny, precise cut or hole requires a small nozzle. If the blast pattern is not critical, a large nozzle is preferred. With larger nozzle openings, more abrasive can flow, and thus cutting speed is increased and efficiency will improve.

Comco offers many different sizes and configurations (see Figure 3-2 and Table 3-4), from a 0.015" diameter round nozzle, to 0.012" x 0.150" rectangular. For most applications a round nozzle would be preferred due to the precise spray pattern. However when abrading large areas, a rectangular nozzle may be used as a "brush" or "fan", which accomplishes such jobs faster than could a round nozzle. Narrow cuts may be obtained with much less trouble and at greater speed if a rectangular nozzle is used and properly oriented with respect to the cut. This may require fixturing if precision is required.

As shipped from the factory, the MB1000 has the 0.030" diameter (green) nozzle installed in the handpiece. This nozzle will provide the best cutting for general applications and will handle all of Comco's abrasives (except walnut shells).

Nozzle Selection

The nozzles provided with your MicroBlaster are chosen because of their wide range of applications. However, since every application is different, these nozzles may not always give the best results. For this reason, many different nozzle sizes and configurations are available for different cutting purposes (see Table 3-4). All are fabricated from the hardest grade of long wearing tungsten carbide bonded into aluminum holders.

Nozzles and holders which turn the abrasive flow 90 degrees are often useful and are available for some sizes. Comco can also custom-engineer special nozzles for unique applications.

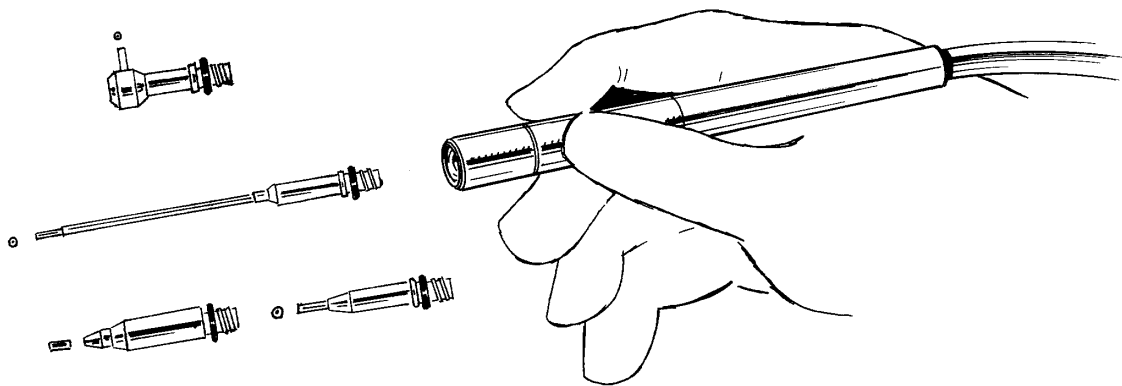

Figure 3-2: Changing the Nozzle

Table 3 - 4: Nozzle Chart ^[1]

HIGH PERFORMANCE NOZZLES (ROUND) - MB1520							
Part No.	Holder Color	Size I.D.	Size I.D. mm	Tip O.D.	Tank Orifice	Abrasive (Microns)	Comments
-24	Violet	.018	0.4	.046	.018 - .025	20 - 50	Medium Cuts
-11	Green	.030	0.7	.074	.025 - .040	20 - 100	Large Cuts
-29	Yellow	.046	1.1	.120	.025 - .040	25 - 200	Large Cuts
-35	Red	.060	1.5	.125	.030 - .040	25 - 300	Large Cuts
STANDARD ROUND NOZZLES - P/N MB1500							
-10	Silver	.015	0.3	.046	.018 - .025	10 - 25	Small Cuts/Holes
-24	Violet	.018	0.4	.046	.018 - .025	20 - 50	Medium Cuts
-27 ^[2]	Black	.018	0.4	.034	.018 - .025	20 - 50	Medium Cuts
-37	Orange	.025	0.6	.061	.018 - .030	20 - 50	Medium Cuts
-11	Green	.030	0.7	.074	.025 - .040	20 - 100	Large Cuts
-29	Yellow	.046	1.1	.120	.025 - .040	25 - 200	Large Cuts
STANDARD RECTANGULAR NOZZLES - P/N MB1500							
-26	Orange	.008x.020	0.2x0.5	.046	.018 - .025	10 - 25	Small Cuts
-12	Blue	.008x.040	0.2x1.0	.074	.018 - .025	10 - 50	Fan, Small Cuts
-19	Red	.008x.060	0.2x1.5	.095	.018 - .025	10 - 50	Fan, Medium Cuts
-20	Silver	.008x.080	0.2x2.0	.120	.018 - .025	10 - 50	Fan, Medium Cuts
-22	Olive	.008x.125	0.2x3.1	.175	.018 - .040	10 - 50	Fan, Large Cuts
-23	Black	.008x.150	0.2x3.8	.195	.018 - .040	10 - 50	Fan, Large Cuts
-32	Blue	.012x.150	0.3x3.8	.195	.025 - .040	20 - 80	Large Cuts
ROUND NOZZLES W/EXTENDED CARBIDES - MB1503 (1.5" LONG)							
-1	Violet	.018	0.4	.066	.018 - .025	20 - 50	Medium Cuts
-2	Green	.030	0.7	.094	.025 - .040	20 - 100	Large Cuts
-3	Yellow	.046	1.1	.157	.025 - .040	25 - 200	Large Cuts
90° ANGLE NOZZLES - MB1501							
-25	Violet	.018	0.4	.046 ^[3]	.018 - .025	20 - 50	Medium Cuts
-14	Green	.030	0.7	.074 ^[3]	.025 - .040	20 - 100	Large Cuts
-28	Yellow	.046	1.1	.120 ^[3]	.025 - .040	25 - 200	Large Cuts
-15	Blue	.008x.040	.02x1.0	.074 ^[3]	.018 - .025	10 - 50	Fan, Small cuts

[1] Dimensions are in inches unless noted otherwise.

[2] Used for special circumstances only.

[3] Overall width is approximately 1/2".

- Standard Nozzle thread configuration is 10-32.

Nozzle Distance

The velocity at which the abrasive particles are expelled from the nozzle produces a well-defined stream that only flares about 7 - 10 degrees. Therefore, the distance the nozzle is held from the work surface will determine the size of the blast pattern as well as the material removal rate (or cutting action). Generally, as the nozzle is moved closer to the work, the blast pattern decreases and the material removal rate increases. What this means is, the distance the nozzle is held from the work surface will determine whether you get a deep, narrow cut with well defined edges, or just a light abrasion over a large area.

Abrading vs. Cutting

The width of the cut or hole produced by a round nozzle will be approximately the same diameter as the nozzle, if the distance is less than 5 times the diameter of the nozzle opening. Likewise, the cut width will increase to 3 times the nozzle diameter at a distance of 25 times the opening and to 5 times at a distance of 40 times the opening. Increasing the distance of the nozzle, the walls of a cut or hole will become increasingly tapered and the top edge will be more rounded. At very long distances (over several inches) there will be very little cut definition, but rather a general "blasting" of the surface. Most cleaning and peening operations are done in this manner.

Although cutting action increases as the nozzle is moved closer to the work surface, it should be noted that the material removal rate reaches a maximum when the spacing between the nozzle tip and the work is about 5-8 times the nozzle opening diameter. Moving the nozzle closer than this tends to start slowing the cutting rate as particles bounce back and collide with each other. Also, as the hole becomes deeper, the diameter will increase due to abrasive working on the sides of the cut. Deep holes or cuts with relatively straight sides may be obtained if the cut is interrupted frequently and excess abrasive removed.

These rules change somewhat for rectangular nozzles since the abrasive flow is more of a fan and the cut character is more a function of the smaller dimension of the rectangle than the greater width. Rectangular nozzles offer the advantage of a very narrow cut without the disadvantage of very slow cutting.

Angle of Approach

Typically, a nozzle held perpendicular to the work surface is only done for precision drilling applications. In most cases, it is far easier to obtain the desired results from abrasive blasting with a nozzle held at an angle. The resulting blast pattern when the nozzle is at an angle to the work surface does not tend to dig holes or produce sharp edge cuts.

As the nozzle is tipped at an angle to a surface, the cutting of a groove will improve, since the action is self-cleaning. In this manner, a saw cut may be made with relatively straight sides through relatively thick materials. In any case, nozzle angle can be adjusted in two planes to result in at least one side being cut perpendicular to the surface.

Air Pressure

The simplest method of changing cutting speed is to vary the air pressure to the tank with the “Air Pressure” adjustment knob. Increasing the pressure increases the velocity of the abrasive particles. Therefore, the higher the pressure, the faster the work surface will be abraded. It should be mentioned that the nozzle, hose, and fittings might also wear at a faster rate under higher pressure conditions.

Powder Flow Adjustment *

Cutting speed and surface texture is affected by media concentration. The best concentration can only be determined by testing each application. The abrasive flow circuit from the tank incorporates a media concentration adjustment labeled “Powder Flow” on the front panel (see Figure 3-4). This adjustment controls the amount of clean, abrasive-free air that is mixed with the outgoing abrasive air stream from the tank. Turning the knob clockwise increases the media concentration. As the knob is turned counterclockwise, from the “MAX” position, more and more clean air is added, reducing the quantity of abrasive in the outgoing air stream. Begin with the knob in the “MAX” position then gradually adjust the knob counterclockwise until the desired cutting rate is achieved.

Bypass Orifice

The bypass tube (see Figure 3-1) in the tank acts as a pneumatic short circuit between the mixing chamber and the upper surface of the powder. If this tube is partially or completely plugged, the pressure differential across the tank orifice is increased and powder flow is increased. For this reason, a special orifice, MB1021, is included with the accessory kit. Powder flow will be increased 10 to 25% when this orifice is screwed into the top of the bypass tube. This method of powder flow adjustment should only be used as a last resort, since it tends to waste a lot of powder.

* Not applicable to older models.

General Operation of the MicroBlaster

This section gives step-by-step procedures on how to use the MicroBlaster. Before proceeding, make sure you have:

- ✓ Reviewed the safety precautions in the introductory selection of this manual.
- ✓ Properly set up your MicroBlaster according to the procedures in Section 2.
- ✓ Selected the proper abrasive for your application.
- ✓ Installed the proper tank orifice for the abrasive powder you are using.
- ✓ Selected the proper nozzle for your application.

Before You Begin

1. Check the tightness of the tank cover. The o-ring seal must be firmly seated against the tank.
2. Check to see that the end of the tank vent hose is inserted into the back of the WorkStation or dust collector hose.
3. Depress the tank cover flapper (see Figure 3-3), and using the funnel from the accessory kit, pour the selected abrasive powder into the tank, filling it at least half full. **Do not overfill.** Tap the flapper as it closes so that any powder on it will be dislodged into the tank and not interfere with sealing of the o-ring.
4. Reposition hoses in the pinches by about 2". It should become a habit to move the hoses through the pinches on a regular basis. This will allow the pinch to squeeze the hose in a different spot, increasing the life of the hoses.
5. Maintain a generous loop in the abrasive hose between the abrasive pinch valve and the hose connection on the rear panel.

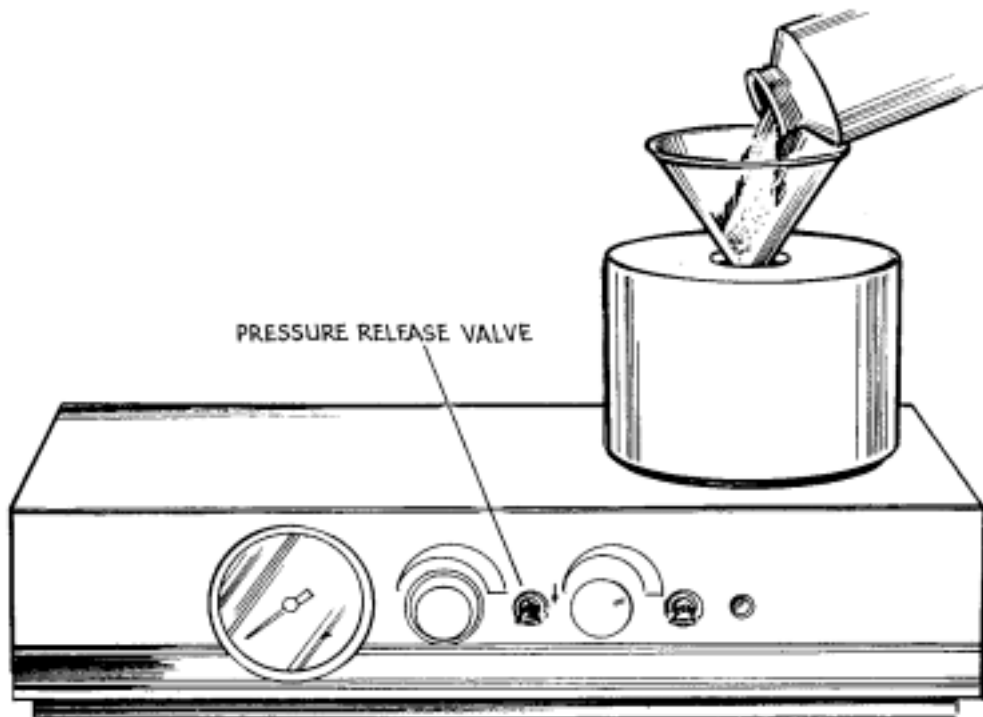
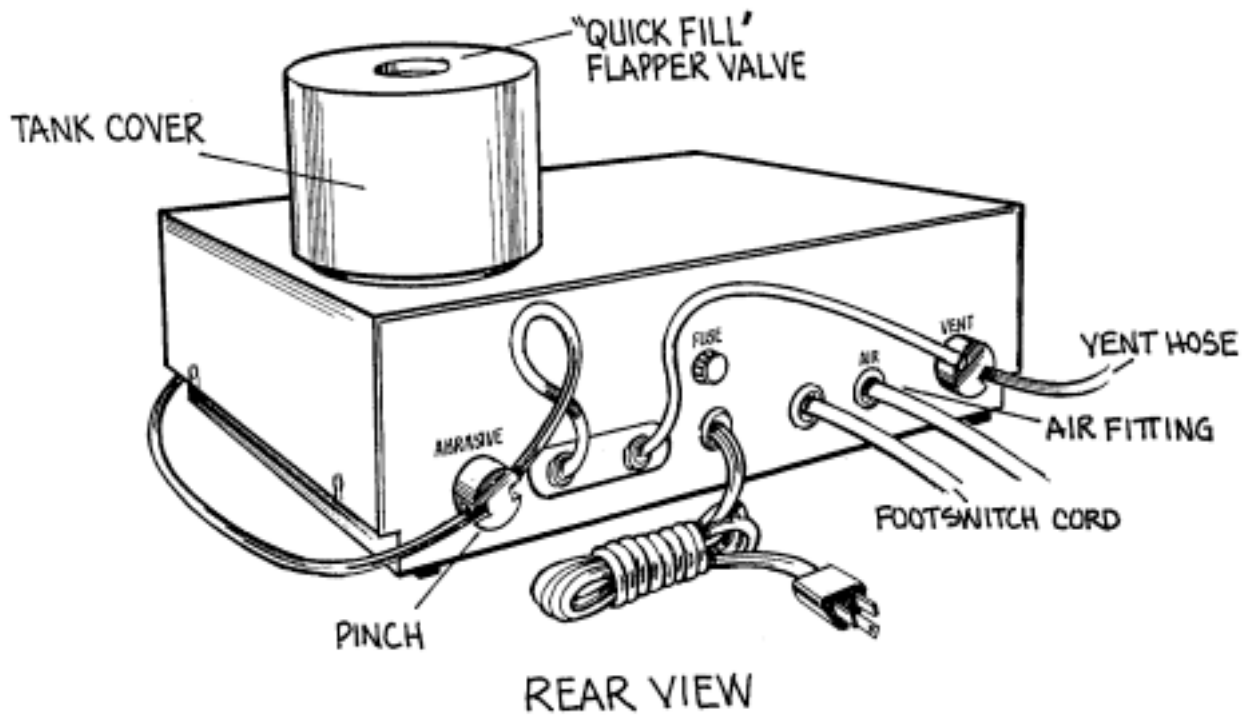
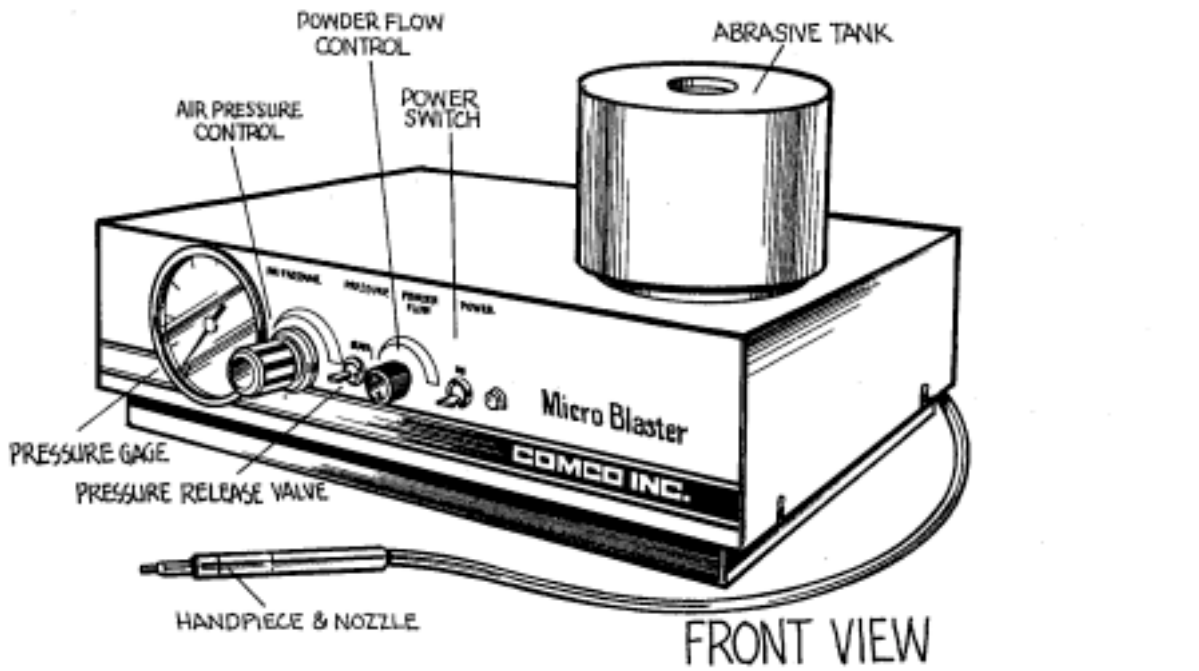

Figure 3-3: Filling the Abrasive Tank

Figure 3-4: Controls and Indicators



Power Up

1. Switch "Power" to the "ON" position. The Power indicator should light.
2. Check to see that no air is escaping from the tank cover. If a leak is discovered, follow the "Stopping-Refilling the Tank" procedure presented later in this section.
3. Adjust the "Powder Flow" knob to "MAX" (fully clockwise).
4. Adjust the "Air Pressure" knob as necessary until the needle on the pressure gage is centered at about 80 psi. Turning the knob clockwise raises the pressure. If the needle indicates a higher operating pressure than desired, it will not lower as the knob is turned counterclockwise, until the footswitch is depressed and air is flowing from the handpiece.

Blasting

1. Place the work piece in the WorkStation. The window will provide a suitable transparent barrier between the operator's face and the work piece to prevent flying abrasive particles from entering the eyes, nose, or mouth.
2. Turn on the dust collector that is connected to the WorkStation.
3. Install the appropriate nozzle in the handpiece, being sure that the o-ring is in place, and firmly seat the nozzle finger tight. The machine is initially equipped with a 0.030" diameter nozzle (green), which is suitable for most abrasives and cutting purposes.
4. Make sure the handpiece is inserted into the WorkStation through one of the side openings. Grasp it firmly as if it were a pencil, aiming the tip of the nozzle at the work piece. The tip should be about 1/4" to 1/2" away from the surface to be blasted (optimum distance for cutting is 5-8 times the nozzle outlet diameter).

CAUTION:

The air that comes out of the nozzle contains abrasive. Do not point the nozzle at anything that could be harmed or damaged as a result of abrasive flow, especially the WorkStation glass window.

5. Step on the footswitch to start blasting. The abrasive pinch valve will open and the modulator will start to hum. Abrasive will continue to flow as long as the footswitch is pressed. Move the handpiece or the work piece as required by the job.
6. If more or less abrasion is desired, turn the "Air Pressure" knob to raise or lower the pressure as abrasive is flowing.
7. To change cutting speed, type of cut, or surface finish produced, experiment with nozzle distance and angle of the nozzle with respect to the surface of the work piece. Refer to Table 3-1 and the beginning of this section for factors that affect abrasive blasting results.

Blasting (cont'd)

8. During use, maintain a generous loop in the abrasive hose between the abrasive pinch valve tube and the hose connection on the rear panel. A tight (small) loop may cause rapid wear to the hose and result in premature failure.
9. During normal blasting, it is good practice to keep the powder flowing continuously. However, under some circumstances, it may be desirable to "pump" the powder by periodically releasing the footswitch for a few seconds. Due to the nature of the modulating process in the mixing chamber, this procedure may cause spurts of abrasive powder and increase the cutting rate. Normally it will only work with relatively large nozzles, since spurts of powder may plug smaller nozzles.
10. The speed and quality of a cut can be affected by the concentration of abrasive media in the air stream. This is adjustable using the powder flow adjustment knob (on some models). Turning the knob counterclockwise decreases the media concentration.
11. When finished blasting, you may shut down the MicroBlaster by pressing the Power switch to "OFF", and depress the Pressure Release switch. The tank pressure will vent through the vent hose.

Note: If the stop is only for a short period, the power may be left on. Standby power loss is small and no damage will result to the equipment with pressure on the system.

Stopping - Refilling the Tank

1. To shut down the MicroBlaster switch, "Power" to "Off".
2. Depress the "Pressure Release" lever for three to five seconds. Air will escape through the front of the valve. The remainder of the air in the powder tank will escape through the vent hose.
3. The tank may be refilled as soon as the pressure drops to zero and the flapper opens easily. Insert the funnel into the Flapper valve (see Figure 3-3) and pour in the abrasive. Do not overfill the tank.
4. A tank 3/4 full will last 3-8 hours depending on nozzle size, pressure, and actual running time. The capacity of the tank can be doubled or tripled with the addition of the optional MB1090 tank extender (see Figure 13, Appendix B).

Changing the Abrasive

1. Turn Power "OFF" and release pressure (see steps 1 and 2, above).
2. Unscrew and remove the tank cover.

Changing the Abrasive (cont'd)

3. Empty the remaining abrasive into a suitable waste container by tipping the machine on its side. Alternately, slip the dust collector hose off the WorkStation and use it to vacuum the inside of the tank and cover. **Do not try to save this abrasive.**
4. Wipe or vacuum off all abrasive on the tank top surface, threads, and inside cover.
5. Spray the tank threads with dry lubricant, if required (see Section 4).
6. Replace the tank cover. Tighten firmly by hand to seat the o-ring seal.

CAUTION:

Thread engagement is important. See Section 4, under "Tank Cover Threads," for additional information regarding thread wear and the Comco supplied thread gage.

7. Turn the Power "ON" to pressurize the unit. Hold the handpiece and depress the footswitch for approximately 30 seconds to purge any remaining abrasive out of the system.
8. Follow the directions in "Stopping - Refilling the Tank", above.

NOTE: Always start the work shift with fresh abrasive powder. Powder left sitting in an unpressurized machine over night can absorb moisture. This contaminated powder can cause flow problems. Keep powder containers sealed and stored in a cool, dry place.

Section 4: Maintenance

In This Section

This section tells you how to maintain your MicroBlaster in peak operating condition, including:

- ◆ Maintenance intervals.
- ◆ Extending the life of wear items.
- ◆ Replacing worn out components.

Normal Maintenance

General Notes

The maintenance intervals given in this section are intended for use as guidelines only. The machine's frequency of use will determine how often these maintenance items will need to be performed. Contact Comco if you have questions.

Note the following cautions before beginning any maintenance or repair task:

- ◆ Unless specifically directed otherwise, ALWAYS depressurize the unit and unplug it before removing the cover or doing any maintenance or repairs.
- ◆ There may be sharp edges inside the cabinet, which could cause injury to personnel or damage to components.
- ◆ Observe all safety precautions provided within this manual.

Tools

In addition to standard hand tools, the following items may be required for maintenance of the MicroBlaster:

- √ A small stiff brush for cleaning threads and components.
- √ The Go-No Go thread gage (supplied by Comco in the accessory kit).
- √ A dry lubricant. Comco recommends a Teflon powder spray, P/N ST8062.

Table 4-1: Maintenance Intervals

Interval	Item	Maintenance
Daily	Hoses	Reposition hoses in pinches.
Weekly	Nozzles	Inspect nozzle tips for wear. Replace if necessary.
	Tank Cover	If the tank cover is removed frequently to change abrasive, lubricate with a <u>dry</u> lubricant (see directions below).
Monthly	Tank Cover	Clean and lubricate (see directions below). Inspect o-rings and threads. Check for leaks.
	Modulator	If the MicroBlaster is used heavily, it may be necessary to inspect the modulator for wear on a monthly basis (see directions below).
	Handpiece Nose	Inspect the Handpiece Nose for wear. Replace if necessary.
	Tank Orifice	Inspect tank orifice for excessive wear or clogging.
	Air Dryer	Service Air Dryer. Inspect powder storage conditions.
6 months to 1 year	Modulator	Inspect the modulator for wear (see directions in section 5).
	Hose Connectors	Inspect hose connectors for wear. Replace if necessary (see description below).
	Entire Unit	Inspect the power cord and footswitch cable. Remove the cover and check for internal leaks (see description below).
	Pinch Assemblies	Inspect pinch assemblies for worn or inoperable parts.

NOTE

With an abrasive machine, wear to critical parts is inevitable. The MicroBlaster Tune-Up Kit contains all the parts you need to conduct routine maintenance and keep an inventory of items that you can replace yourself. Comco recommends that these parts be replaced annually, or every 2000 hours of operation, whichever comes first. Establishing and following a regularly scheduled maintenance program for your equipment, can reduce costly downtime. A well maintained MicroBlaster delivers a more consistent powder flow, minimizes processing time, and actually saves you money by reducing powder consumption. Contact Comco's Customer Service Department (see section 5, page 2) and order part number MB1440 to get a Tune-Up Kit for your MicroBlaster today.

Parts Subject to Normal Wear

All the parts through which the abrasive flows are subject to wear. These include the nozzle, hose, hose connector, and tank orifice. As a general rule, the smaller the opening through which the abrasives must flow, the greater the possibility of wear. Parts also subject to wear are the tank cover (threads) and modulator.

Hose

On a daily basis (or more often with heavy usage), hoses should be moved about 2" through the pinch assemblies on the back panel (with air pressure off), increasing the size of the loop. This will allow the pinch to squeeze the hose in a different spot. The movement will greatly increase the life of the hoses. When the hoses have been moved 6", the direction of movement through the pinch should be reversed.

NOTE: Care should be taken to maintain a 4-5" diameter loop in the hoses from the fitting on the back panel to the pinch tube. Sharp bends will cause excessive hose wear.

At weekly intervals, with the machine off and depressurized, squeeze the handpiece abrasive hose between thumb and forefinger in the area where the pinch valve has been operating, and along the first 2 - 3 inches adjacent to the fitting at the rear panel. It should be evenly firm along its length, without any soft spots. Whenever a soft spot is detected, the hose should be cut back to that point and reattached to the fitting. See the procedures in Section 5 to repair or replace the hose.

Hose Connectors

The connectors that attach the hose to the rear panel of the MicroBlaster are also subject to abrasive wear. Be sure to check them each time you replace hoses. Refer to Section 5 of this manual when replacing hose or hose connectors.

Nozzles

Although manufactured from the hardest grade of tungsten carbide, nozzles are usually subject to the greatest wear. They may start to bellmouth (widen) within a few hours and be 50% oversize within a day, depending on the aggressiveness of the abrasive powder, the pressure, and the duty cycle. Refer to Section 3 of this manual when changing nozzles.

Tank Orifice

The orifice controls the amount of abrasive deposited into the mixing chamber. Over time, the orifice may become enlarged, allowing too much abrasive powder into the air stream, causing clogging of small nozzles.

Parts Subject to Normal Wear (cont'd)

Modulator

The modulator is an electro-mechanical device that is activated each time the footswitch is depressed. The stop/start action of the modulator contributes to a consistent flow of abrasive powder from the tank into the mixing chamber and out the nozzle. The principles of operation are described in detail in Section 1 of this manual.

Due to its constant movement and its close proximity to the abrasive in the mixing chamber, the mechanical part of the modulator, the modulator housing assembly, is considered a wear point and should be inspected on a regular basis. The frequency, with which the modulator should be inspected, depends on machine usage. Applications that include heavy use, or very aggressive abrasives, may require checking the modulator on a monthly basis. In light use, or mild abrasive applications, inspection should be done every six months. It is recommended to replace the modulator housing assembly every 2000 hours of operation, which is approximately one year of normal operation. See Section 5 for inspection and repair procedures.

Pinch Tube and Plunger

The pinch tube and plunger are the parts of the pinch assembly that make contact with the hose. Hoses can sometimes develop leaks at the point where they are pinched. Leakage of abrasive at these points can cut into the pinch tube and plunger causing sharp edges that damage hoses. Inspect the pinch tube and plunger for sharp edges every time you replace a hose (see Figure 4-1). Abnormal hose breakage, always at the pinch, is an indication of pinch tube or plunger failure. See Section 5 for replacement procedures.

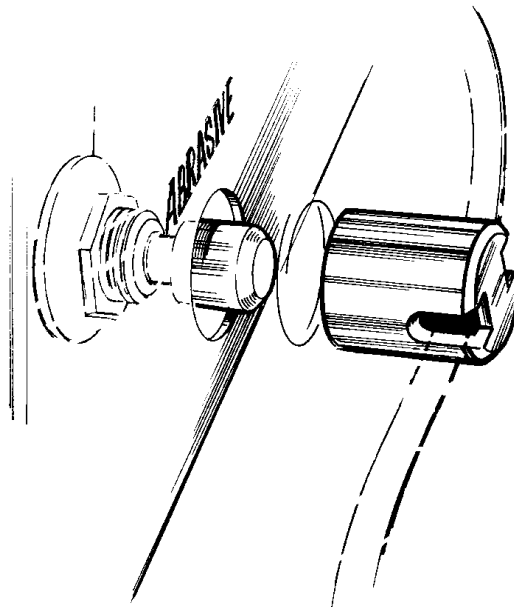

Figure 4-1: Pinch Tube and Plunger Inspection

Parts Subject to Normal Wear (cont'd)

Tank Cover

The tank cover seals the abrasive tank and allows for replenishing the abrasive powder. ***Always fill the tank through the flapper valve and refrain from removing the tank cover unless absolutely necessary.*** Whenever the tank cover is removed to change powder, excess powder must be brushed off the top of the tank and out of the threads. A small stiff brush is ideal for this purpose.

At weekly intervals (or as necessary), spray or wipe a dry lubricant such as graphite, molybdenum disulfide, or Teflon powder on the tank threads (order Comco P/N ST8062). If an aerosol dispenser is used, or the lubricant is suspended in a solvent, allow a few minutes for the solvent to dry before installing the cover.

Always check to make sure the tank cover is firmly tightened. If the tank cover is not firmly seated so that the o-ring seals properly, abrasive can be forced out by the system pressure and seriously damage both the tank and cover. Perhaps the most serious consequence of this situation is the jamming of the cover to the tank, making it impossible to remove. Whenever this occurs, it is best to send the unit back to the factory for repair.

Inspect the tank cover monthly for worn o-rings and threads. If the o-rings become worn, order the Comco o-ring kit, part number MB1450.

Tank Cover Threads

As the tank cover is twisted on, any abrasive trapped between the tank and the tank cover threads tends to grind the threads a small amount. Since the MicroBlaster tank is a pressurized device, this action may eventually reduce the thread engagement to a danger point. Always clean the tank and tank cover threads before installing the cover.

Included in the accessory kit is a "Go-No Go" thread gage. Use this gage monthly to verify that the tank cover thread wear is within acceptable limits. **If the thread gage drops into the threaded section of the tank cover exposing more than 2 threads (see Figure 4-2), replace the cover at once. Failure to do so may lead to structural failure under pressure resulting in possible injury.**

HAZARD:

Failure to use the thread gage or to take the corrective actions described above may result in a hazardous condition.

**Figure 4-2:
Instructions for Testing Tank Cover Threads**

1. De-pressurize the MicroBlaster by turning 'OFF' and unscrew the tank cover. Place the red thread gage (part no. MB1435) inside the lid so that it drops over the threaded area.
2. If the thread gage will not enter the threaded area, or if fewer than two (2) threads are exposed, the tank cover is safe to continue using.
3. If the thread gage slips into the threaded area exposing more than two (2) threads, **REPLACE THE TANK COVER AT ONCE.**
4. Our new tank cover is manufactured using larger, square threads and a new O-ring design that reduces wear and requires less maintenance. When occasional maintenance is required it is easier to perform. Contact Customer Service and request the Tank Adaptor Ring (part no. MB1550) and our new Tank Cover (part no. MB1568) to upgrade your MicroBlaster today.
5. Remove the thread gage and store it in a convenient location. Test your tank cover monthly.

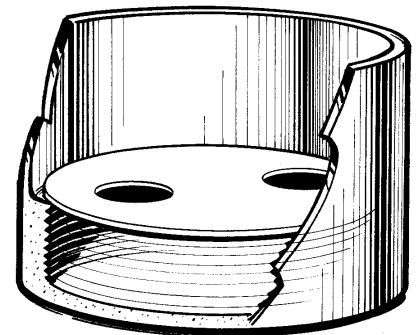
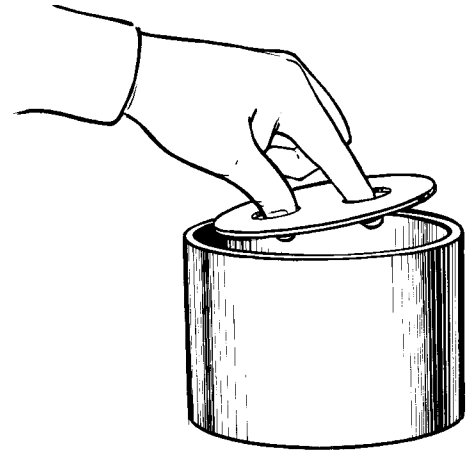

Acceptable

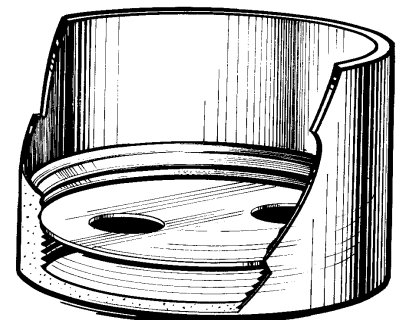

Unacceptable

Cabinet and Cables

At six-month intervals, unplug the power cord and inspect it for cracks or cuts. Also check the footswitch cable. Remove the cabinet cover and inspect the inside of the MicroBlaster for obvious leaks. Clean thoroughly with a small brush and vacuum hose (never use air or try to blow off abrasive).

Leaks

During normal operation, air may be used at the rate of 1-1.5 cubic feet per minute, depending on nozzle size and air pressure. Small leaks can increase air usage considerably and reduce the efficiency of the MicroBlaster. A large drop in pressure while the machine is operating can be an indication of an air leak.

Leaks usually begin to occur first in the tank cover o-rings. Inspect the o-rings often and make sure the cover is firmly sealed. See the previous discussion on "Tank Cover", in this section. See Section 5 for further information on leaks.

Moisture

Contamination of the abrasive powder due to moisture is one of the most common problems associated with micro-abrasive blasting. Moisture causes the powder to "clump up", preventing it from flowing freely from the tank. Though no fault of the MicroBlaster, it will not work efficiently if the abrasive you put in it becomes contaminated by moisture. If the cutting action of your MicroBlaster appears to be degraded but air is flowing freely from the nozzle, the problem is usually caused by moisture in the abrasive powder. See Section 5 for information on how to check for moisture in the powder.

Where the Moisture Comes From

Moisture can contaminate your powder in two ways: before it is put into the machine, or after it is put into the tank. If your powder is stored in an area of high humidity, or the containers are not kept properly sealed, you are putting contaminated powder into your MicroBlaster, which will cause poor performance. Inspect your powder storage facility and handling procedures on a monthly basis.

Abrasive powder should never be exposed to moist air with a relative humidity in excess of 40% for more than a short time. Contaminated abrasive powder should be discarded. Under some circumstances, if done very carefully, some abrasive powders may be dried by placing the material in a warm oven (220-250°F) for several hours. **This procedure cannot be used with sodium bicarbonate.**

The abrasive powder could also become contaminated with moisture after it has been put into the MicroBlaster. If the unit sits depressurized for long periods of time, moisture can enter through the Quick Fill valve and contaminate the powder. To prevent this form of contamination, fill the tank with only the amount of abrasive you expect to use that day. Only fill the tank at the beginning of the work shift. Don't fill the tank and let it sit overnight.

Moisture (cont'd)

The most common cause of moisture contamination, however, comes from the air compressor that feeds the MicroBlaster. Water condensation occurs in compressed air no matter how low the relative humidity might be. For trouble-free operation, the air that mixes with abrasive media must have less than 200 ppm moisture and less than 10 ppm oil. The water traps of most compressors are not sufficient to provide this level of dryness. A positive air dryer should always be installed in the air line and it should be well maintained. Inspect the air dryer monthly to be sure it is operating properly.

Old or poorly maintained air compressors are also a source of oil contaminants in the air supply. Oil in the air supply will not only affect abrasive flow, it can cause major component failures within your MicroBlaster, resulting in costly repairs. If you suspect oil in the air supply, you should install an oil filter in the line, in addition to an air dryer.

Comco maintains an extensive library of technical bulletins that address issues including the effects of moisture on the micro-abrasive blasting process and methods for reducing moisture contamination. They are available by contacting Customer Service at 1-800-796-6626 or by viewing our website – www.COMCOinc.com – to download an electronic copy.

Auxiliary Equipment

The MicroBlaster rarely operates as a stand-alone unit. As discussed in Section 2, a micro-abrasive blasting system usually contains a dust collector, a WorkStation, and an air dryer, along with the MB1000. Optimum operation of the MB1000 is in many ways dependent upon proper operation of its auxiliary components. Detailed operation and maintenance procedures for these units are contained in each individual unit's instruction manual. Only basic maintenance concerns are mentioned here as part of an overall system maintenance plan.

Dust Collector

Empty the spent abrasive from the dust collector on a regular basis. Typically, this should be done monthly. However, in high use facilities, it should be done weekly.

WorkStation

Make sure the WorkStation has good air draw and remains clear of abrasive build-up. If abrasive begins to build up, refer to the above paragraph on "Dust Collector". Keep the glass window clean and replace it if it becomes damaged by abrasive. Refer to Appendix C for more information.

Air Dryer

This is the most critical auxiliary unit to optimum MB1000 operation (see the section on "Moisture"). Desiccant air dryers should be checked for moisture saturation, usually indicated by a change in color. Other types of air dryers should be checked according to the manufacturer's recommendations. Check the system air dryer on a regular basis. Typically, this should be done monthly. However, in high use facilities, it should be done weekly.

Section 5: Trouble-shooting and Repair

In This Section

This section tells you how to handle any problems that may occur with your MicroBlaster, including:

- ◆ What to look for if your MicroBlaster does not operate properly and how to determine the specific problem.
- ◆ How to correct most problems that may develop with the MicroBlaster.
- ◆ How to contact Comco's Customer Service Department.
- ◆ How to order replacement parts for the MicroBlaster.

Trouble-shooting

This section explains what to do if you have any problems with the MicroBlaster. The first part of the section describes some of the problems that may occur with micro-abrasive blasters, and the second part contains detailed repair procedures.

NOTE: **Improper repairs may void your warranty. If you have any questions, consult with Comco before you do any work on the inside of the MicroBlaster MB1000.**

Most problems that can occur with your MicroBlaster will fall into either one of two categories:

- 1) No air flow - Nothing happens when you depress the footswitch. Neither air nor abrasive is expelled from the nozzle.
- 2) No abrasive flow - Air flows freely from the nozzle when the footswitch is depressed. However, there appears to be no abrasive in the air stream, or it flows erratically.

The tables that follow address each of these conditions specifically.

Advanced Trouble-shooting

This manual is designed to provide only basic operation and maintenance information. For our customers who use MicroBlasters in high production environments, and who routinely do all of their own maintenance, Comco has developed a comprehensive Trouble-shooting and Repair Guide. To order the MicroBlaster Trouble-shooting and Repair Guide, contact Comco Customer Service at the number listed below, and ask for the book number MB1444.

Customer Service

Comco's Customer Service Department is open Monday through Friday from 7:00am to 4:30pm, Pacific Time, to help you with any problems you may have with your MicroBlaster. The telephone numbers and FAX number are listed below:

Phone: 1-800-796-6626
-or- 1-818-841-5500

FAX: 1-818-955-8365

You may also e-mail your questions to:

techsupport@COMCOinc.com

How To Order Replacement Parts

Replacement parts for the MicroBlaster may be ordered directly from Comco Customer Service. Please provide the following when ordering parts:

- ◆ Your name
- ◆ Your company's name and location (city and state)
- ◆ The machine, model number, and serial number
- ◆ The part number of the component you wish to order

Providing this information will expedite your request and will also ensure that you receive the proper component for your unit.

Repair Kits

Comco offers **Repair Kits** for its customers who prefer to do their own maintenance. These kits contain the parts and instructions needed to keep your MicroBlaster in top condition.

Tank Cover O-ring Kit (MB1450) replace worn o-rings in the tank cover, to provide a proper seal.

MicroBlaster Tune-up Kit (MB1440) replace all normal wear points in your MicroBlaster.

Contact Comco for more information.

Common Problems, Causes, and Solutions

Table 5-1: No Air Flow

Problem	Items to Check	Solution
<p>Nothing happens when the footswitch is depressed</p> <p>(No air is coming out of the nozzle)</p>	<p>√ <i>Is the electrical power ON?</i></p>	<p>Verify that the POWER switch is ON and the POWER LIGHT is illuminated.</p>
	<p>√ <i>Is the fuse good?</i></p>	<p>Examine the fuse. Replace if necessary.</p>
	<p>√ <i>Does the gage indicate pressure in the system?</i></p>	<p>Verify that shop air pressure of 80-140 psig is supplied to the MicroBlaster.</p>
	<p>√ <i>Is the nozzle plugged?</i></p>	<p>Remove the nozzle and depress the footswitch. If a blast of abrasive occurs, the nozzle was plugged. Tap it on the workbench, back end down. Discard the nozzle if it remains plugged.</p> <p>If plugging recurs, either the tank is releasing too much powder or the nozzle is too small for the powder.</p>
	<p>√ <i>Is the pinch valve opening?</i></p>	<p>The abrasive hose should slide freely through the abrasive pinch tube when the footswitch is actuated. If it does not, the valve is not functioning properly. See maintenance of the pinch valve below.</p>

Common Problems, Causes, and Solutions (cont'd)

Table 5-2: No Abrasive Flow

Problem	Items to Check	Solution
Cutting ceases but air is flowing freely	√ <i>Is <u>any</u> abrasive flowing?</i>	Verify the quality of abrasive flow by holding a piece of glass or shiny metal in front of the nozzle and depress the footswitch. If there is no abrasive flow, see below. If flow is erratic, see "Modulator".
	√ <i>Is the tank empty or almost empty?</i>	Switch "Power" to "Off". Release the system pressure with the "Pressure Release" lever. Fill the tank as necessary.
	√ <i>Is the powder "channeling"?</i>	Carefully remove the tank cover without disturbing the powder in the tank. Note if there are obvious holes or cracks in the powder, leading down to the orifice. This is caused by damp powder or moisture in the air supply. Check the air supply and the powder storage conditions. Service the air dryer, or install one.
	√ <i>Is the tank orifice plugged?</i>	Remove the powder in the tank following normal procedures. Remove the orifice and hold it up to the light. If blocked, clean with high-pressure air or a small wire.
	√ <i>Is the tank orifice too small for the powder?</i>	Small orifices should not be used with some abrasives (see Section 3, Table 3-3).
	√ <i>Is the Modulator functioning?</i>	Does it hum audibly when the footswitch is actuated? If not, or if it rattles noisily, the modulator should be checked. See procedures below.

NOTE: Always start the work shift with fresh abrasive powder. Powder left sitting in an unpressurized machine overnight can absorb moisture. This contaminated powder can cause flow problems. Keep powder containers sealed and stored in a cool, dry place.

The Handpiece Nose

The handpiece nose is the main part of the handpiece that holds the nozzle. The nose holds together the abrasive hose, handpiece tube and the nozzle. Abrasive will wear away the inside of the nose to a point where it can no longer support the hose. Also, if the nozzle is not tightened firmly into the nose, abrasive leakage will wear away the threads and the nozzle will not fit properly.

Handpiece Nose Replacement Procedure (MB1230-1)

1. Remove the nozzle and o-ring.
2. Unscrew the handpiece tube from the nosepiece and slide it back.
3. Remove the hose from the nosepiece (it may be easier to cut hose).
4. Slip the hose onto the nosepiece. Sometimes a little moisture helps.
5. Screw on the handpiece tube.
6. Install the nozzle.

The Abrasive (Blue Poly) Hose (refer to Appendix B, Figure 8)

An obviously worn or burst abrasive hose may be cut back slightly beyond the problem area in order to be reused. If this cannot be done, the hose should be replaced. The entire abrasive hose handpiece assembly (MB1083-3) can be replaced, or individual pieces, as necessary.

CAUTION: Always use the proper hose when replacing a worn or damaged abrasive hose. The use of a different hose or a hose with a different pressure rating may present a hazard.

Abrasive Hose Replacement Procedure

1. Turn the power off, depressurize the unit, and unplug the power cord.
2. At the rear panel of the MicroBlaster, loosen the hose connector nut from the connector using a 7/16" open-end wrench and remove the hose.
3. Remove and save the connector nut and rubber grommet from the old hose.
4. Pull the hose through the pinch tube.
5. Inspect the hose connector for wear, replace if necessary.
6. Inspect the pinch tube and pinch plunger as described below.

Abrasive Hose Replacement Procedure (cont'd)

7. Feed a 6 ft. length of new hose MB1233 (or the old cut back hose) through the pinch tube.
8. Slip the rubber grommet (ST5010) and the connector nut onto the hose.
9. Work the end of the hose onto the hose connector fitting, and tighten the nut onto the connector using a 7/16" open-end wrench. It is only necessary to tighten the nut enough to clamp the hose to the fitting's tube.

Hose Connector Fittings

When installing replacement fittings that have pipe threads, use a small amount of thread sealing compound or tape to insure leak free joints.

CAUTION: Using improper fittings, or fittings that have been improperly installed or assembled, can present a hazard.

Hose Connector Replacement Procedure (MB1455*)

1. Turn the Power OFF and depressurize unit.
2. At the rear panel of the MicroBlaster, cut the hose approx. 3" from connector.
3. Using a 7/16" open-end wrench, remove the hose connector.
4. Attach the new hose connector MB1455* to rear of unit. Tighten with a 7/16" open-end wrench.
5. Slide the connector nut onto the hose. Tighten the nut onto connector using a 7/16" open-end wrench. It is only necessary to tighten the nut enough to clamp the hose to the fitting's tube.

*MicroBlasters with serial numbers below 6000 may require Comco P/N ST4014.

Hose Failure at the Pinch

During normal operation, the hose pinch will open and close frequently. This action weakens the hose at the squeeze point and leads to eventual hose failure. Refer to Section 4 of this manual, "Normal Maintenance", for detailed information on reducing this type of failure.

If for some reason the pinch does not close tightly enough to completely seal the hose, a very slight leak can rapidly wear through the hose and cause it to leak. Should this occur, the pinch must be examined and the problem corrected. See: "Inspecting and Repairing the Pinch Valve", below.

Pinch Tube and Plunger

The pinch tube and plunger are the parts of the pinch assembly that make contact with the hose. Hoses can sometimes develop leaks at the point where they are pinched. Leakage of abrasive at these points can cut into the pinch tube and plunger causing sharp edges that damage hoses. Inspect the pinch tube and plunger for pitting and sharp edges every time you replace a hose. Abnormal hose breakage, always at the pinch, is an indication of pinch tube or plunger damage.

Pinch Tube and Plunger Inspection

1. Turn off, depressurize, and unplug the MicroBlaster.
2. Remove the hose from the connector and pull it through the pinch tube (see replacement procedure, "Abrasive Hose", above).
3. Remove the pinch tube. Inspect it for sharp edges or pitting due to abrasive leakage. Replace if necessary with Comco part number MB1282.
4. Inspect the pinch plunger for sharp edges or pitting due to abrasive leakage. Replace if necessary with Comco part number MB1050-2.
5. Install the pinch tube. The pinch tube should be hand tightened all the way on to the cylinder and then backed off about 1/4 turn until the hole is horizontal.
6. Install the hose - see procedure, above.

Inspecting and Repairing the Pinch Valve (refer to Appendix B, Figure 9 and Figure 10)

Proceed as far as necessary according to the problem.

1. Turn the Power OFF and depressurize the unit.
2. Remove the blue poly hose from the hose fittings and pull through the pinch tube.

Inspecting and Repairing the Pinch Valve (cont'd)

3. Unscrew the pinch tube completely (Item 3). Inspect the pinch tube and pinch plunger as described above.
4. Inspect the piston rod by pulling it out about 2". It should be clean, dry (not oily), and not "gritty". Wipe thoroughly. The rod should retract easily when released. Note that the Abrasive Pinch has a 10-15 second delay.
5. Install the pinch tube. It should be hand tightened all the way on to the cylinder and then backed off about 3 turns until the hole is horizontal. Install the hose (see procedure, above).

If required, replace the pinch assembly according to the following procedure:

Pinch Assembly Replacement Procedure

1. Unplug the MicroBlaster and remove the cover (4 screws).
2. If removing the abrasive pinch assembly, disconnect the solenoid wires from the electrical terminals and mark the terminals in order to replace the new connections correctly.
3. Disconnect the air hose (depending on the model, you must unscrew the connector nut, or push down and hold the red retaining ring and pull the hose out).
4. Turn the MicroBlaster on its side.
5. Remove two screws from the bottom of the unit and remove the pinch.
6. Install a new pinch with the pinch tube extending out through the back of the unit.
7. Tighten the screws and place the MicroBlaster flat on the table.
8. Reconnect the air hose. Make sure it is firmly in place.
9. Replace the wires to the terminal board, if necessary (polarity is not important).
10. Install the abrasive hose (see Replacing Abrasive Hose procedure above).
11. Replace the cover.

Pinch Delay Adjustment

The abrasive pinch assembly is equipped with a delay valve (flow control) to prevent it from opening for 10 - 15 seconds after internal pressure is released. This allows the tank pressure to escape through the vent hose, rather than the nozzle. If the abrasive pinch opens too quickly when depressurizing, tighten the screw on the flow control. Refer to Appendix B, Figure 10. If already tight, it will be necessary to replace the flow control.

Inspecting and Repairing the Modulator (refer to Figure 5-1)

Proceed as far as necessary according to the problem.

1. Turn the power OFF and unplug the unit.
2. Remove the tank lid and dump the powder from the tank.
3. Remove the MicroBlaster cover (4 screws).
4. Loosen the nut on the modulator hose fitting and detach the hose from the modulator.
5. Using a 7/8" open-end wrench, remove the coil retaining nut from the modulator housing. Slide the coil and 1" washer off the modulator housing. **Save the washer.**
6. With a 7/16" open-end wrench across the two flats of the modulator nose, remove the modulator nose from the stainless steel body.
7. Examine the polyurethane seat cemented on the modulator nose. It should be smooth and unmarked except for a faint ring (impression) matching the ring seat on the core.
8. Tip the tank and allow the core to slide out. Note the core's orientation, the cross-holes must be nearest the tank.
9. Examine the edges and ring seat of the core. They must be smooth and even. If it has any scratches or roughness that can be felt with a fingernail, replace the entire Modulator Housing Assembly MB1301-2. If neither the nose seat nor the core is worn, reassemble the modulator housing assembly and skip to step 13.

Note: Make sure the core is inserted properly into the housing. The cross-holes must be nearest the tank.

Figure 5-1:
Modulator Assembly and Modulator Housing Assembly

MODULATOR ASSEMBLY

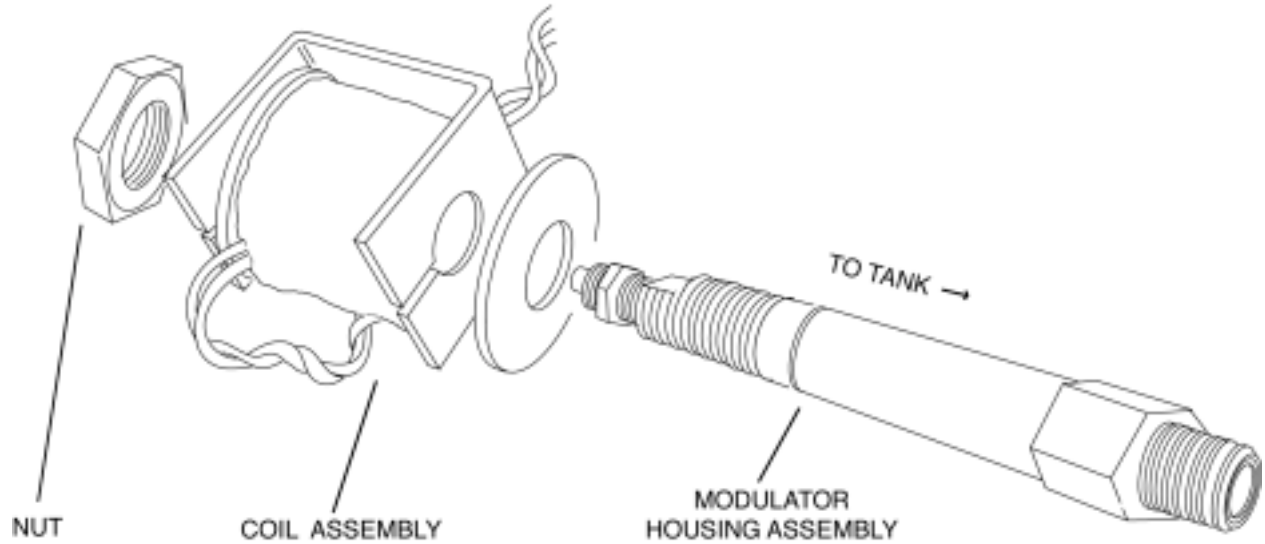

MODULATOR HOUSING ASSEMBLY

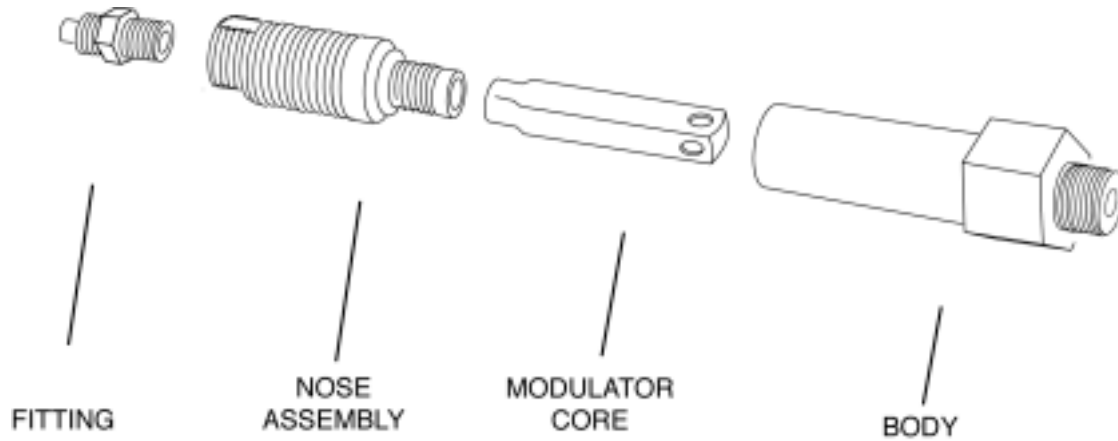

Inspecting and Repairing the Modulator (cont'd)

10. Using a 5/8" open-end wrench, remove the modulator housing from the tank.

Note: If it is difficult to reach the housing, it may be necessary to remove the tank to allow better access to the modulator housing. Turn the MicroBlaster on its side and remove the three screws from the bottom of the unit that hold the tank legs in place. The tank will lift out, providing access to the modulator coupling.

11. Use a vacuum to remove any residual powder from inside the tank mixing chamber (at the modulator connection).
12. Make sure threads are clean and abrasive free. Install the new modulator housing (P/N MB1301-2) to the tank. Tighten with a 5/8" open-end wrench.

Note: If the tank was removed per Step 10, replace it now.

13. Slide the 1" washer over the modulator housing and then slide the modulator coil over the modulator housing. Make sure that the end of the coil with the wires attached is closest to the tank.
14. Screw on the 7/8" coil retaining nut and tighten.
15. Remove the hose connector nut from the modulator and slide it onto the air hose. Slip the end of the air hose onto the modulator hose connector. Tighten the nut with a 7/16" open-end wrench.
16. Replace the MicroBlaster cover.
17. Install the tank cover.

Moisture

If the cutting action of your MicroBlaster appears to be degraded but air is flowing freely from the nozzle, the problem is usually caused by moisture in the abrasive powder.

How to Check for Moisture in the Powder

With the Power OFF and the unit depressurized, carefully remove the tank cover so as not to disturb the contents. Is the powder "channeling"? In other words, are there obvious holes or cracks through an apparently solid mass or clumps of powder? If so, you have a moisture problem. See Section 4, "Moisture", on how to prevent moisture from contaminating your powder.

Clogging

Moisture or particulate matter contamination in the abrasive powder can cause clogging problems in your MicroBlaster. The most likely place for clogging to occur is in the tank orifice. Provided the orifice is sized properly for the type of abrasive being used (see Section 3, "Orifice Selection"), the powder should always flow freely from the tank.

Since the tank orifice is the only way for the powder to get from the tank to the mixing chamber, a clog here restricts or prevents powder flow. If air is flowing freely when the footswitch is depressed but there seems to be no abrasive in the air stream, check the tank orifice (see Section 3, "Changing the Tank Orifice"), remove it, clean if necessary. Observe for signs of moisture or particulate contamination.

Nozzle

If the unit is pressurizing and you can see the pinch opening when the footswitch is depressed, but no air is flowing from the nozzle, the nozzle is probably plugged. The most likely cause of this is an oversized tank orifice. Too much powder in the air stream can overload the nozzle and cause clogging (see Section 3, Orifice/Nozzle selection).

Remove the nozzle. Check it by holding the tip to a light. A point of light should be visible through the tip. Tap it on the workbench, back end down, to release the clog. Discard the nozzle if it remains plugged.

If plugging recurs, either the tank is releasing too much powder or the nozzle is too small for the powder.

Leaks

Small leaks can increase air usage considerably and reduce the efficiency of the MicroBlaster. A large drop in pressure while the machine is operating can be an indication of an air leak. Check the supply air inlet hose and the supply regulator for leaks. This is a high-pressure line so small leaks can cause the loss of large volumes of air.

If a leak is suspected within the MicroBlaster, switch off the power and watch the pressure gage. Does it remain steady, or does it drop rapidly? Are there any noticeable or audible leaks? Listen near the tank top, pinch, tank vent hose and pressure release switch; or apply a soap solution to these locations and watch for bubbles.

With the cabinet cover removed, are there any noticeable powder clouds or audible leaks near fittings? If necessary, switch the power on to re-pressurize the unit, and then off again.

CAUTION: There is High Voltage at the Terminal Block!!

It is very hard to detect a slight leak in the tank cover. If you cannot locate a leak anywhere else, it is probably the tank cover o-rings. See the following discussion, "Tank Cover".

Air Pressure Regulator Assembly

The Air Pressure (Cutting Speed) regulator adjusts the source air pressure down to a useful blasting pressure as indicated by the gage. The regulator assembly contains the regulator, check valve, filter and hose fittings. Refer to Appendix B, Figure 11.

Indications of a regulator failure:

- a) Gage goes to "Max" at idle but drops drastically when blasting.
- b) Regulator knob will not turn in either direction.
- c) Regulator knob turns freely, but never tops or bottoms out (no high or low stop).

Replace the Regulator Assembly according to the following procedure:

Air Pressure Regulator Assembly Replacement Procedure (Refer to Appendix B, Figure 11, or contact Comco for part number.)

1. Turn Power OFF and depressurize unit.
2. Remove the MicroBlaster cover (4 screws).
3. Using a 7/16" open-end wrench, remove the hose connector nuts and hoses from the regulator assembly. You may want to label each air hose before removing.
4. Remove the retaining nut from the front of the regulator.
5. Pull the regulator assembly back into chassis and remove.

NOTE: It may be necessary to remove the cap from the knob in order for it to fit through the front panel. Squeeze the sides of the cap and pop it off (similar to removing a child-proof cap from a pill bottle). You will need to do the same with the new regulator. There is a spacer underneath the cap. Be sure to replace it before replacing the cap.

6. Install the new regulator with the filter up.
7. Attach the tubing to the regulator assembly and tighten the nuts.
8. Install the cover.

Tank Cover

The tank cover seals the abrasive tank and allows for replenishing the abrasive powder by filling through the “quick access” flapper valve. ***Always fill the tank through the flapper valve and refrain from removing the tank cover unless absolutely necessary.*** The tank cover should be well maintained to ensure a good seal. Inspect the tank cover regularly for worn o-rings and threads, or pitting due to abrasive leakage. See Section 4 for procedures to check the tank cover threads with the thread gage provided in the accessory kit. If the tank cover threads become worn, replace it with Comco p/n MB1068.

Tank Cover Flapper Valve

The flapper valve allows for quick filling of the abrasive tank. If the valve becomes worn or damaged, replace it with Comco part number MB1145.

Tank Cover Flapper Valve Replacement Procedure (MB1145)

1. Turn Power OFF and depressurize unit.
2. Unscrew the tank cover and remove.
3. Using a 3/32” Allen wrench, remove the flapper valve. Replace the o-ring if necessary; see procedure below.
4. Install the new flapper valve (MB1145).
5. Install the tank cover.

Tank Cover O-ring Replacement Procedure (MB1450)

1. Remove the flapper valve according to steps 1 through 3 above.
2. Insert the tip of a screwdriver under the inner edge of each tank o-ring and remove.
3. Pour a small amount of acetone into the o-ring grooves and let soak a few minutes.
4. Clean the acetone and dissolved adhesive from o-ring grooves. Dry thoroughly.
5. Use a small amount of acetone on a clean towel to wipe new o-rings clean. Dry thoroughly before installation.
6. Use the tube of adhesive (ST8318) provided with the kit to inject a light bead of adhesive around the bottom of the o-ring grooves.

Tank Cover (cont'd)

7. Press o-rings firmly in place. Make sure they are evenly seated all the way around and no adhesive is on top of o-rings. Wipe off any excess.
8. Let adhesive dry for 24 hours.
9. Install the flapper valve.
10. Install tank cover(s).

Replacement Parts Lists

Lists of MB1000 replacement parts, accessories and supplies are provided in this manual as follows:

Items	Location
Accessories: A listing of all components in the accessory kit.	Section 2, Getting Started and Appendix A, Parts Lists
Supplies: Lists of abrasives, nozzles, and tank orifices.	Section 3, Using the MicroBlaster MB1000
Recommended Spare Parts: List of normal wear items.	Appendix A, Parts Lists
Major Assemblies: List of principal parts of the MicroBlaster with breakdown.	Appendix A, Parts Lists and Appendix B, Drawings and Schematics
Parts Details: Includes functional, electrical, and pneumatic schematics.	Appendix B, Drawings and Schematics

Appendix A
Parts Lists
for the
MicroBlaster MB1000

MAJOR ASSEMBLIES AND PRINCIPAL PARTS

<u>PART NUMBER</u>	<u>DESCRIPTION</u>	<u>QTY.</u>
MB1409-25 ^[1]	Orifice, Tank, 0.025"	1
MB1068	Cover, Tank, Assy.	1
• MB1145	Flapper Assy	1
• ST5022	O-Ring, Cover Seal	1
• ST5023	O-Ring, Flapper Seal	1
MB1083-3	Handpiece, Nozzle, Assy.	1
• MB1012-6	Tube, Handpiece	1
• MB1230-1	Nose, Handpiece	1
• MB1233	Hose, Abrasive	6 ft
MB1125	Cover, Standard MicroBlaster	1
MB1157-2	Pinch, Vent Assy.	1
• MB1050-2	Plunger, Pinch	1
• MB1282	Tube, Pinch	1
• MB1384-2	Bracket, Valve	1
• ST4003	Vent, Breather	1
• ST4010	Elbow, 1/4T x 1/8P	1
• ST6081	Cylinder, 1-1/16	1
MB1170	Valve, Bleed, Assy.	1
MB1198-9 ^[2]	Valve, Air, Assy. 115VAC	1
• ST6013-1 ^[2]	Valve, Sol, 2-way, N.C., 115V	1
• ST4006	Connector, 1/4T x 1/8P	1
• ST4029	Coupler, 1/8" P	1
• ST4049	Nipple, 1/8" P	1
• ST4166	Connector, 1/4T x 1/8 MPT, Push-In	1
MB1233	Hose, Abrasive	6 ft.

^[1] Tank Orifice size may be changed by Sales Order.

^[2] 230V Assy is MB1198-10; Valve is ST6013-5

MAJOR ASSEMBLIES AND PRINCIPAL PARTS (cont'd)

<u>PART NUMBER</u>	<u>DESCRIPTION</u>	<u>QTY.</u>
MB1290-7 ^[3]	Modulator, Air, Assy, 115VAC	1
• MB1301-2	Housing, Modulator, Assy	1
▶ MB1294	Core, Modulator	1
▶ MB1307	Nose, Modulator, Assy	1
▶ MB1482	Body, Modulator, MB	1
▶ ST4006	Connector, 1/4T x 1/8P	1
• MB1287	Yoke, Coil	1
• MB1310-1 ^[3]	Coil, Modulator, 115V	1
• ST1006	Nut, 9/16-18	1
• ST1021	Washer, Steel, 9/16 x 1-3/8	1
MB1300-5 ^[4]	Pinch, Abrasive, Assy., 115VAC	1
• MB1050-2	Plunger, Pinch	1
• MB1282	Tube, Pinch	1
• MB1384-1	Bracket, Pinch	1
• ST4003	Vent, Breather	2
• ST4010	Elbow, 1/4T x 1/8P	1
• ST6003-1 ^[4]	Valve, Sol., 3-way, 115V	1
• ST6231	Valve, Flow Control	1
• ST6081	Cylinder, 1-1/16	1
MB1396	Knob, Assy.	1
MB1397-1	Powder Adjustment Assy.	1

^[3] 230V Assy is MB1290-8, Coil is MB1310-2

^[4] 230V Assy is MB1300-6, Coil is ST6003-5

MAJOR ASSEMBLIES AND PRINCIPAL PARTS (cont'd)

<u>PART NUMBER</u>	<u>DESCRIPTION</u>	<u>QTY.</u>
MB1402-13	Cabinet, Assy.	1
• MB1227-1 ^[5]	Socket, Neon, 115VAC	1
• MB1229	Diode, Rectifier	2
• ST7003	Switch, Toggle, DPST	1
• ST7004	Lamp, Neon	1
• ST7005	Holder, Fuse	1
• ST7007-7	Conn. Block Terminal	1
• ST7015	Footswitch, SPST	1
• ST7016 ^[5]	Cord, Power, 115VAC	1
• ST4012	Tube, plastic 1/4"	A/R
• ST7625-010 ^[5]	Fuse, 1 amp	1
MB1403-1 *	Regulator, Cutting Speed, Assy.	1
• MB1319	Filter, Abrasive	2
• MB1376-1	Regulator, 0-125	1
• ST4004	Elbow, Street, 1/8P	1
• ST4010	Elbow, Male 1/4T x 1/8P	1
• ST4011	Tee, Male Run, 1/4T x 1/8P	2
• ST4036	Tee, Female 1/8P	1
• ST4018	Tee, Male	1
• ST4050	Nipple, 1/8P x 1-1/4 Lg	1
• ST6022	Valve, Check, 1/8P	1
MB1404-1 *	Tank, Powder, Assy.	1
• MB1025-5	Tube, Bypass	1
• MB1328-10	Tank, Powder	1
• ST4004	Ell, Street, 1/8P	2
• MB1455	Connector, Quicknut	2
• ST4010	Elbow	1
• ST4110	Nipple, 1/8P x 2-1/2 Lg	1
• ST4130	Elbow, Street, 0.125", 45°	1
• ST4131	Cross	1

^[5] 230 V parts are: Socket MB1227-2; Cord ST7235; Fuse ST7625-005

* Non-standard parts. See individual part drawings, Appendix B, for information on choosing correct part numbers

MAJOR ASSEMBLIES AND PRINCIPAL PARTS (cont'd)

<u>PART NUMBER</u>	<u>DESCRIPTION</u>	<u>QTY.</u>
MB1407-1 ^[6]	Gage, 2.5", 0-160 psi	1
MB1500-11	Nozzle, .030, Green	1
• ST5020	O-Ring, Nozzle	1
ST5465-4	Pin, Spring, 0.062" x 0.250"	1

^[6] MicroBlaster with serial numbers below 8250 order MB1407-3

STANDARD ACCESSORY PARTS, MB1089-11 ^[*]

<u>PART NUMBER</u>	<u>DESCRIPTION</u>	<u>QTY.</u>
MB1500-22	Nozzle, .008 x .125, Olive	1
MB1500-24	Nozzle, .018, Violet	1
MB1500-29	Nozzle, .046, Yellow	1
MB1409-40	Orifice, Tank, .040	1
MB1021	Orifice, Bypass	1
MB1233	Tube, Abrasive, Poly	6 ft
MB1435	Gage, Thread	1
ST4005	Bushing, .250T x.125P, Brs	1
ST4006	Connector, 1/4T x 1/8P	1
ST4012	Tube, Plastic, 1/4	6 ft
ST5066	Funnel, Abrasive	1
ST7625-010 ^[*]	Fuse, 1 Amp	2
PD1003-4	Abrasive, C, 50 micron, Alum Oxide	1 btl.
PD1004-3	Abrasive, D, 50 micron, Glass Bead	1 btl.

^[*] Kit for 230V machines is MB1089-15; Fuse is ST7625-005; Nut Driver ST5114 is added.

OPTIONAL PARTS

<u>PART NUMBER</u>	<u>DESCRIPTION</u>	<u>QTY.</u>
MB1456-1	Extender Tank, Kit, 5"	Opt.
MB1456-2	Extender Tank, Kit, 10"	Opt.
MB1409-18	Orifice, Tank, .018	Opt.
MB1409-30	Orifice, Tank, .030	Opt.
MB1409-40	Orifice, Tank, .040	Opt.
MB1237-3	Splitter, 2-way	Opt.
MB1500-10, etc.	Nozzles, Standard, Various (See Section 3)	Opt.
MB1520-11, etc.	Nozzles, Hi Performance (See Section 3)	Opt.

RECOMMENDED SPARE PARTS (Optional)

<u>PART NUMBER</u>	<u>DESCRIPTION</u>	<u>QTY.</u>
MB1409-x*	Orifice, Tank	2
MB1500-x*	Nozzle	4
MB1301-2	Housing Assy, Modulator	2
ST6022	Check, Valve	1
MB1319	Filter	1
MB1233	Abrasive Hose	30 ft.
MB1230-1	Handpiece Nose	1
MB1455	Connector, Quicknut	4
MB1450	Tank O-ring Kit	1

- * Orifice and Nozzle sizes are determined by application requirements. Refer to Section 3 for details.

Appendix B
Drawings and Schematics
for the
MicroBlaster MB1000

List of Figures

Figure 1: Front View	B-3
Figure 2: Top View	B-4
Figure 3: Pneumatic Schematic	B-5
Figure 4: Electrical Schematic	B-6
Figure 5: P/N MB1068 Tank Cover Assembly	B-7
Figure 6: P/N MB1404-1 Abrasive Tank Assembly	B-8
Figure 7: P/N MB1290-7 (-8) Modulator Assembly	B-9
Figure 8: P/N MB1083-3 Handpiece Assembly	B-10
Figure 9: P/N MB1157-2 Vent Pinch Assembly	B-11
Figure 10: P/N MB1300-5 Abrasive Pinch Assembly	B-12
Figure 11: P/N MB1403-1 Cutting Speed Regulator	B-13
Figure 12A: P/N MB1170 Bleed Valve Assembly	B-14
Figure 12B: P/N MB1198-9 (-10) Air Valve Assembly	B-14
Figure 13: P/N MB1456-1 (-2) Tank Extender Assembly	B-15
Figure 14: P/N MB1237-3 Abrasive Divider Assembly	B-16

FIGURE 1: FRONT VIEW, MODEL MB1000

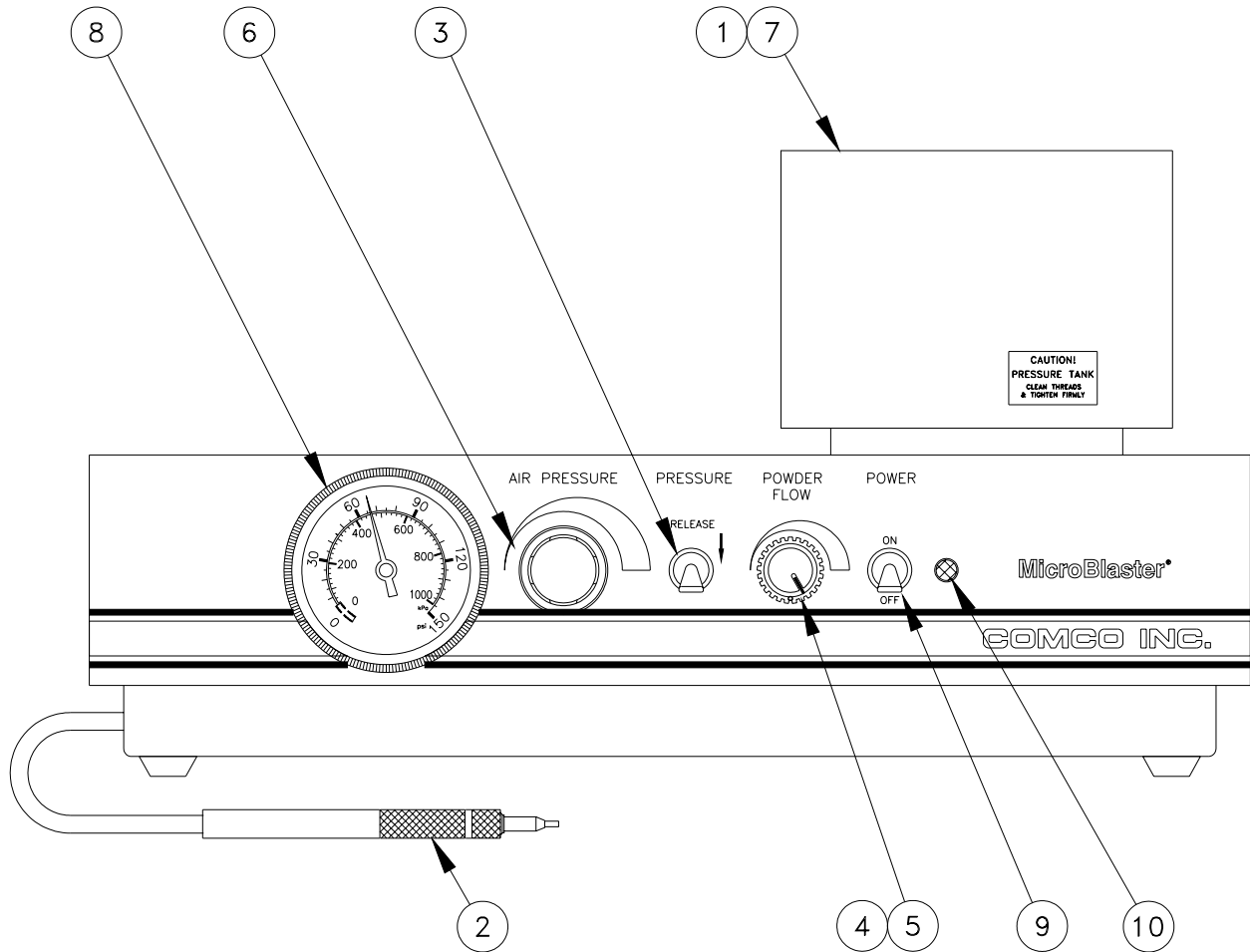

Item No.	Description	Part #	Item No.	Description	Part #
1	Tank Cover	MB1068	6	Air Pressure Reg.	[1]
2	Nozzle Handpiece	MB1083-3	7	Abrasive Tank	[1]
3	Pressure Release	MB1170	8	Gage, 2.5" [3]	MB1407-1
4	Knob Assy [2]	MB1396	9	Power Switch	ST7003
5	Powder Adj Assy [2]	MB1397-1	10	Indicator Lamp	ST7004

[1] See individual Part Drawing for Part Numbers.

[2] Not applicable to Serial No's below 8500.

[3] For MicroBlaster Serial No's below 8250, use Gage MB1407-3.

FIGURE 2: TOP VIEW, MODEL MB1000

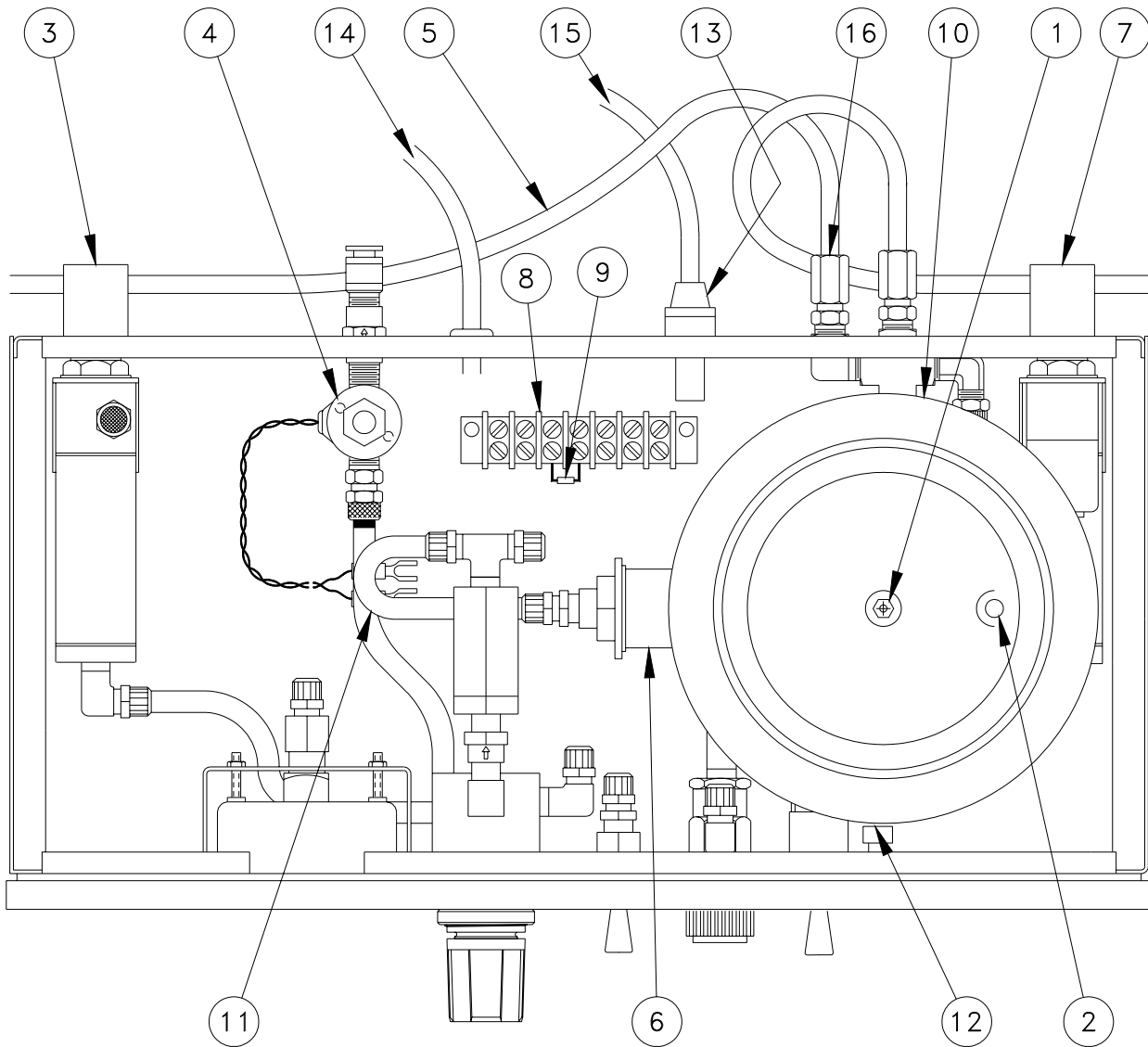

Item No.	Description	Part No.	Item No.	Description	Part No.
1	Tank Orifice	[1]	9	Diode, Assy	MB1229
2	By-pass Tube	MB1025-5	10	Abrasive Tank	[2]
3	Vent Pinch Assy	MB1157-2	11	Tube, Plastic	ST4012
4	Air Valve	[2]	12	Socket, Neon	MB1227-1
5	Abrasive Hose	MB1233	13	Fuse, Holder	ST7005
6	Modulator	[2]	14	Footswitch	ST7015
7	Abrasive Pinch Assy	[2]	15	Power Cord	ST7016
8	Block, Terminal	ST7007-7	16	Quicknut Conn.	MB1455 [3]

- [1] Tank Orifice size may be changed. Refer to Section 3 of the Manual.
- [2] See individual Part Drawing for Part Number.
- [3] For MicroBlaster Serial No. below 6000, use Union ST4014.

FIGURE 3: PNEUMATIC SCHEMATIC, MODEL MB1000

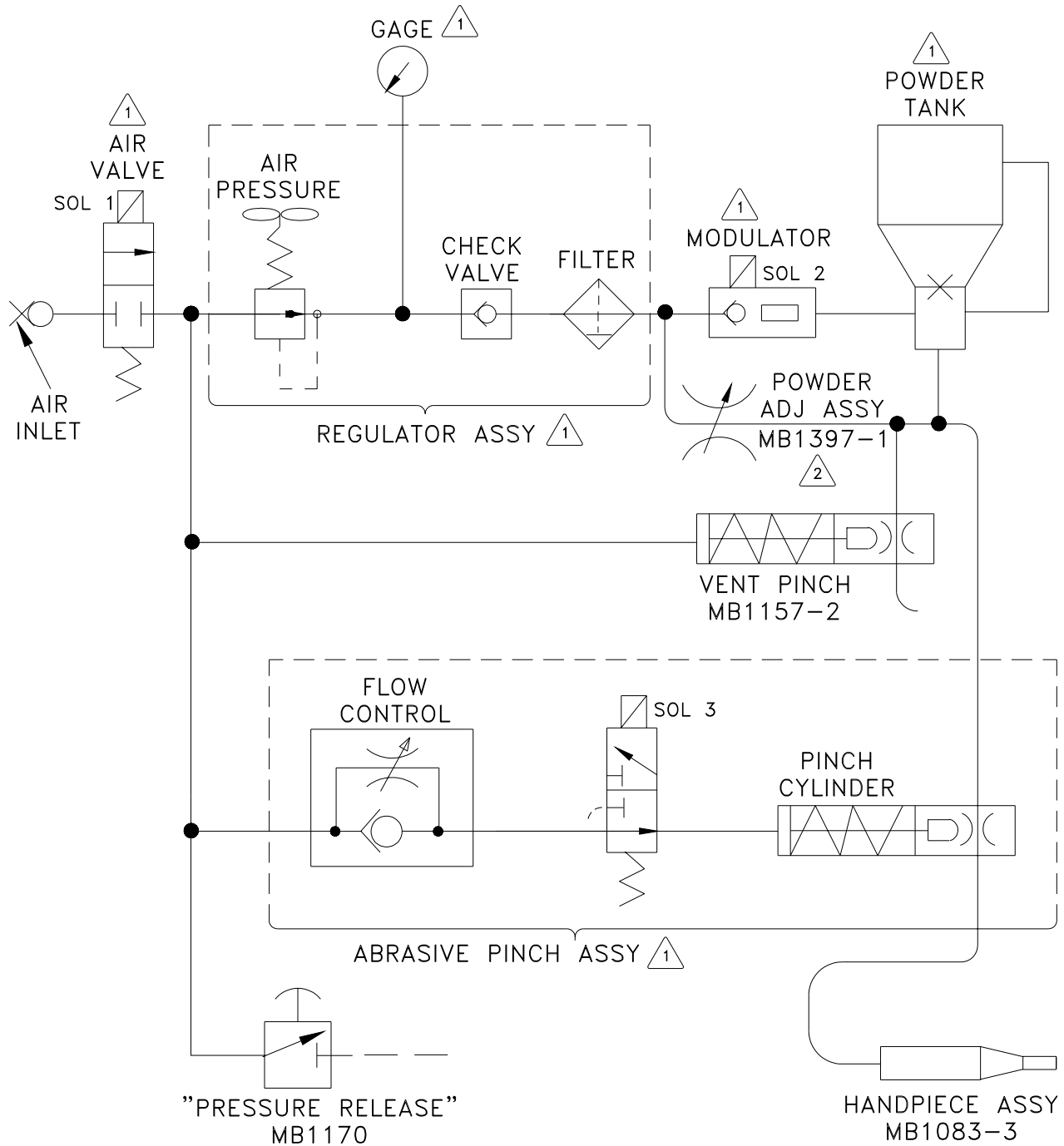

- △1 SEE INDIVIDUAL PART DRAWING FOR PART NUMBERS.
- △2 NOT APPLICABLE TO SERIAL No.'S BELOW 8500

FIGURE 4: ELECTRICAL SCHEMATIC, MODEL MB1000

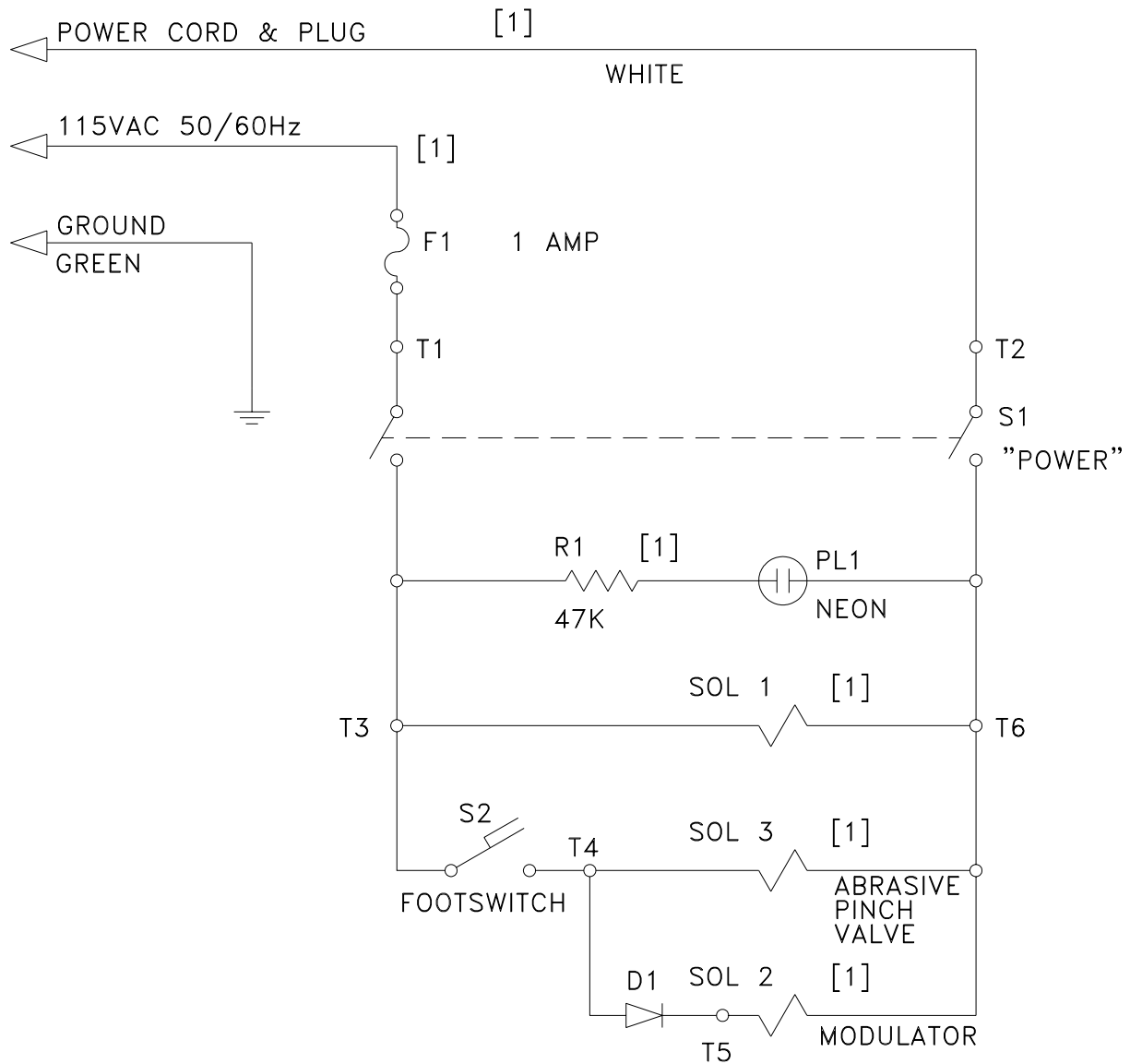

[1] FOR 230V, CHANGE F1 TO 0.5 AMP AND R1 TO 120K.
 CHANGE VALVE COILS, MODULATOR, AND POWER CORD
 AS SPECIFIED BY PARTS LIST

FIGURE 5: P/N MB1068 TANK COVER ASSEMBLY

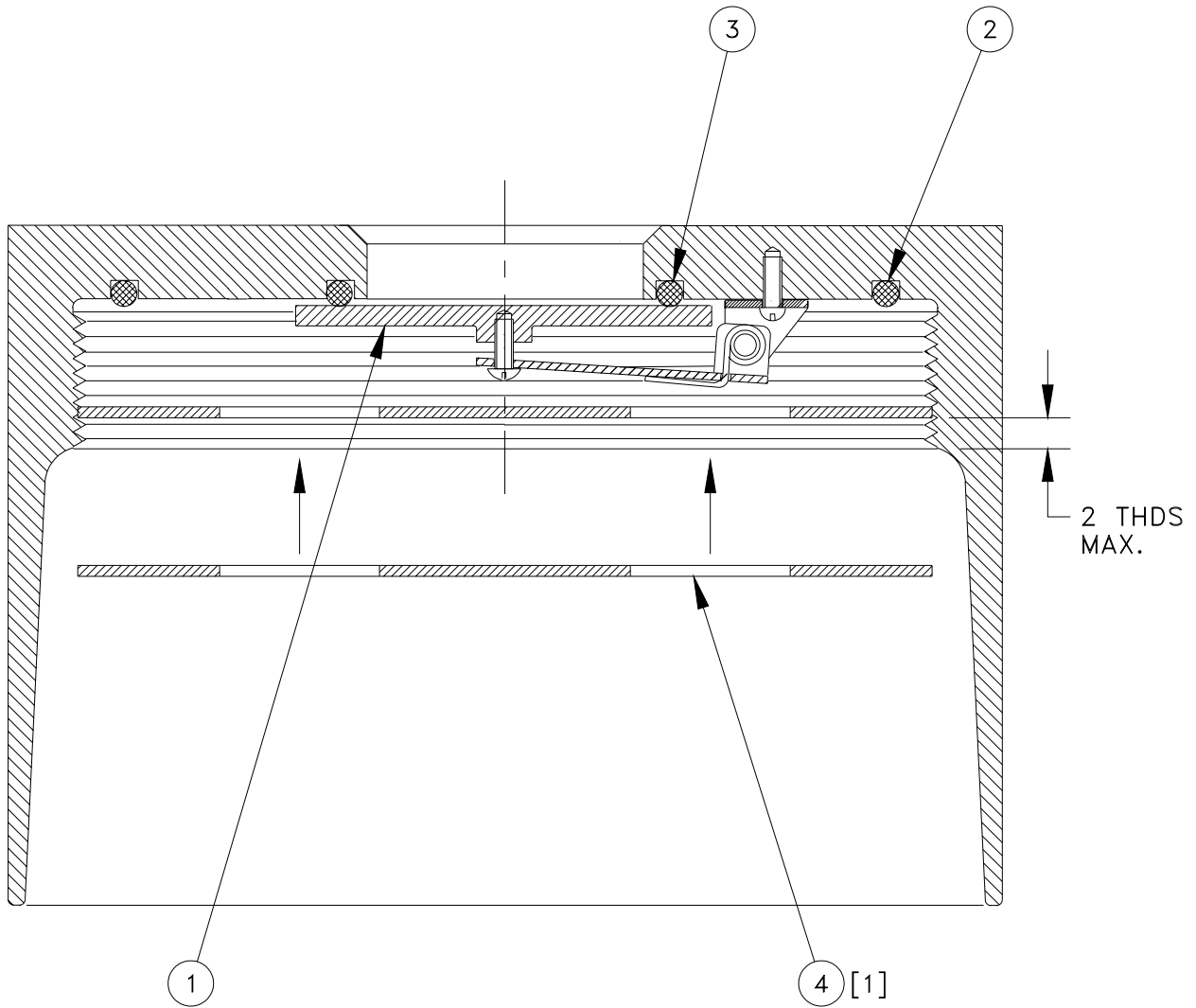

Item No.	Description	Part No.	Qty
1	Flapper, Assy	MB1145	1
2	O-Ring, Cover Seal	ST5022	1
3	O-Ring, Flapper Seal	ST5023	1
4	Gage, Thread [1]	MB1435	1

[1] Item 4 is not part of Tank Cover Assy, MB1068.

FIGURE 6: P/N MB1404-1 ABRASIVE TANK ASSEMBLY

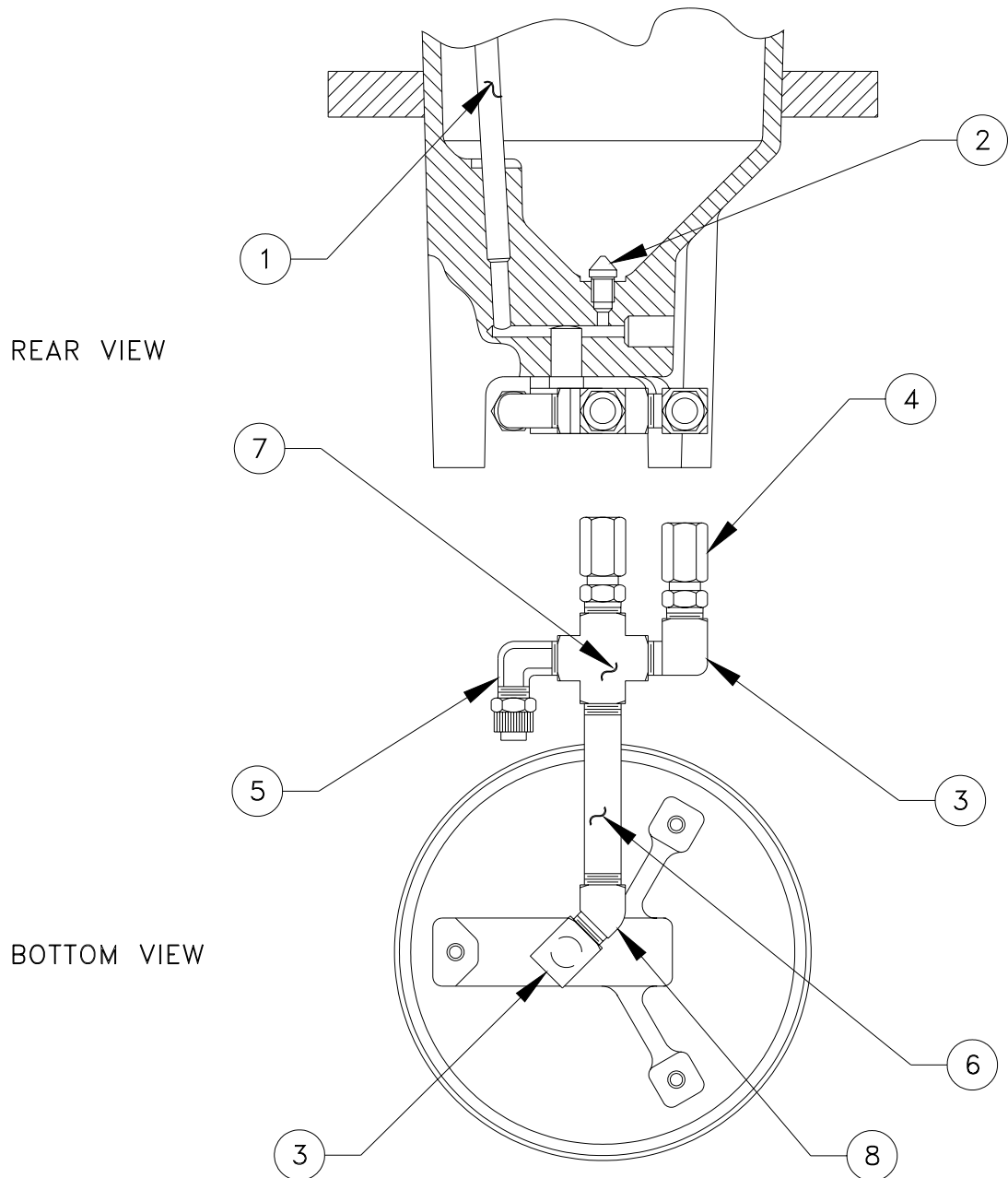

Item No.	Description	Part No.	Qty	Item No.	Description	Part No.	Qty
1	Tube, Bypass	MB1025-5	1	5	Ell, Male, 1/4T-1/8P	ST4010	1
2	Orifice, Tank	[2]	1	6	Nipple .125 x 2.4 Brs	ST4110	1
3	Ell, Street, 1/8P	ST4004	2	7	Cross .12 FNPT	ST4131	1
4	Quicknut, Conn.	Mb1455	2	8	Elbow, St, .125P, 45°	ST4130	1

[1] For MicroBlaster Serial No. 0-5999, use Tank Assy P/N MB1327-1.
 For MicroBlaster Serial No. 6000- 8499, use Tank Assy P/N MB1327-3.
 [2] Tank Orifice size may be changed. See Section 3.

FIGURE 7: P/N MB1290-7^[1] (-8) MODULATOR ASSEMBLY

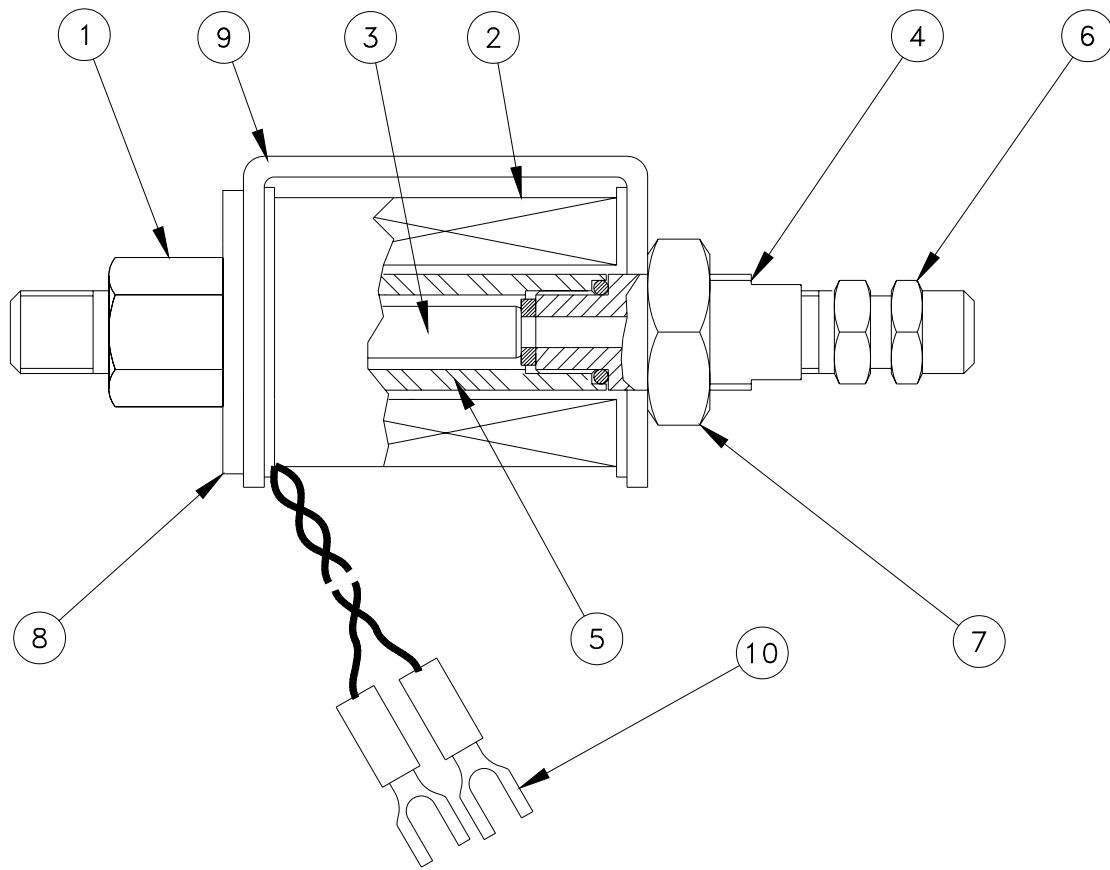

Item No.	Description	Part No.	Qty	Item No.	Description	Part No.	Qty
1	Mod. Housing Assy	MB1301-2	1	6	Conn, M 1/4T-1/8P ^[2]	ST4006	1
2	Modulator Coil ^[3]	MB1310-1	1	7	Nut, Hx Stl 9/16-18	ST1006	1
3	Modulator Core ^[2]	MB1294	1	8	Washer, Flat, 9/16	ST1021	1
4	Modulator Nose Assy ^[2]	MB1307	1	9	Yoke, Coil	MB1287	1
5	Body, Modulator ^[2]	MB1482	1	10	Term, Fork, Crimp	ST7010-1	2

^[1] MB1290-7 is 115V, MB1290-8 is 230V.
^[2] Items 3, 4, 5, & 6, are part of item 1.
^[3] MB1310-1 is 115V Coil, MB1310-2 is 230V Coil.

FIGURE 8: P/N MB1083-3 HANDPIECE ASSEMBLY

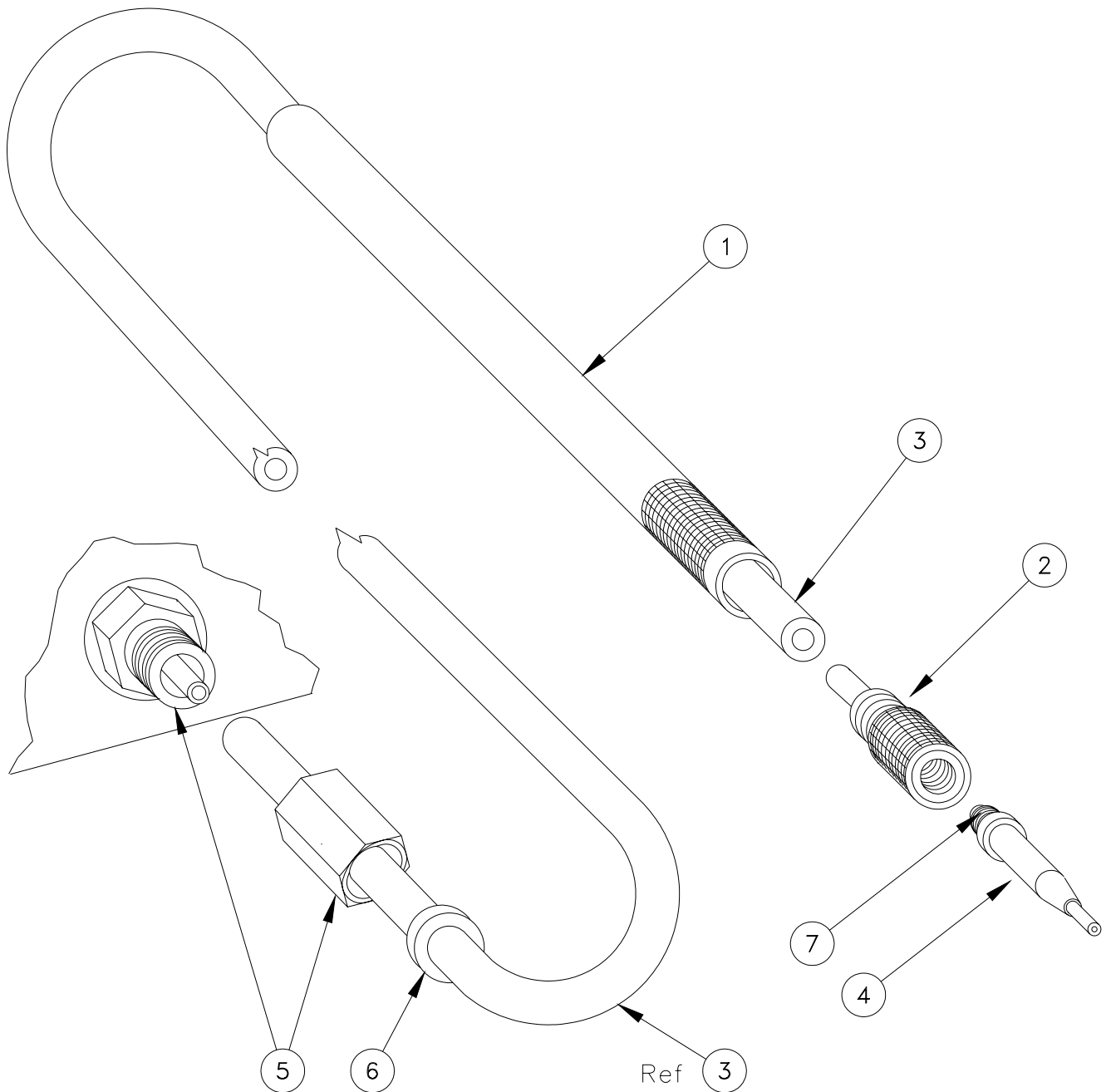

Item No.	Description	Part No.	Item No.	Description	Part No.
1	Handpiece Tube	MB1012-6 [1]	5	Quicknut , Connector (Ref)	MB1455
2	Handpiece Nose	MB1230-1 [1]	6	Grommet, Rubber (Ref)	ST5010
3	Abrasive Hose	MB1233 [1]	7	O-Ring	ST5020
4	Abrasive Nozzle	MB1500- (as req'd)			

[1] MB1083-3 includes items 1, 2 & 3 only.

Rev. 10/02

FIGURE 9: P/N MB1157-2 VENT PINCH ASSEMBLY

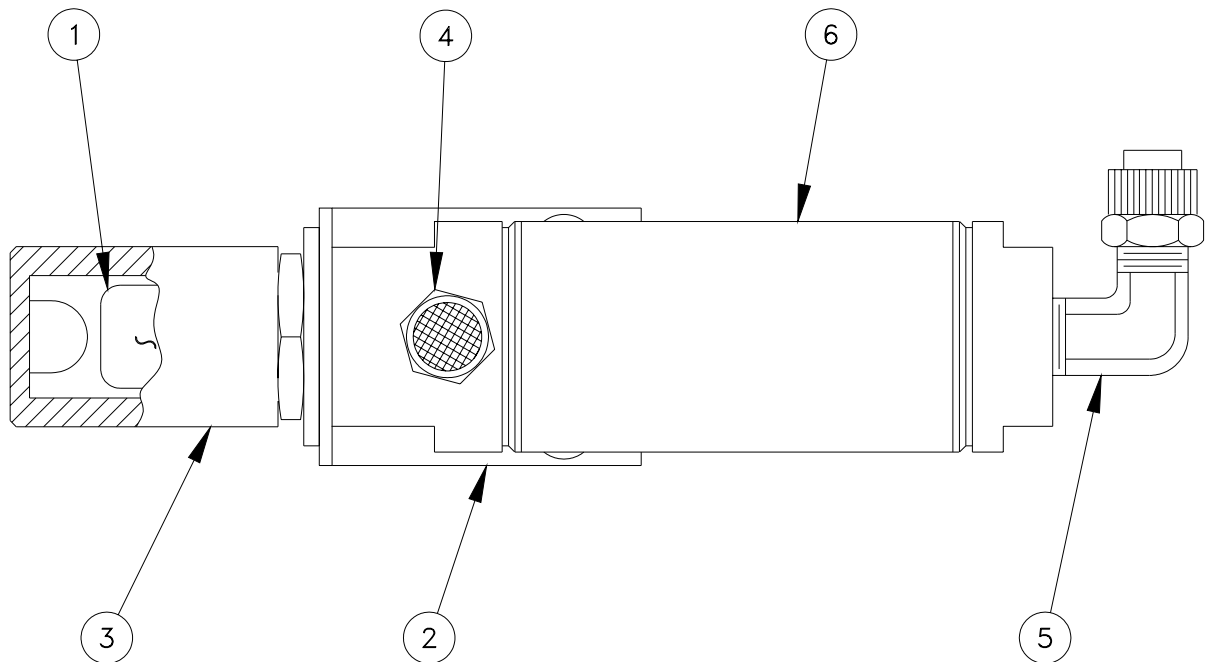

Item No.	Description	Part No.	Item No.	Description	Part No.
1	Plunger, Pinch	MB1050-2	4	Vent, Breather	ST4003
2	Bracket, Pinch	MB1384-2	5	Elbow, 1/4T x 1/8P	ST4010
3	Tube, Pinch	MB1282	6	Cylinder, 1 - 1/8	ST6081

FIGURE 10: P/N MB1300-5^[1] ABRASIVE PINCH ASSEMBLY

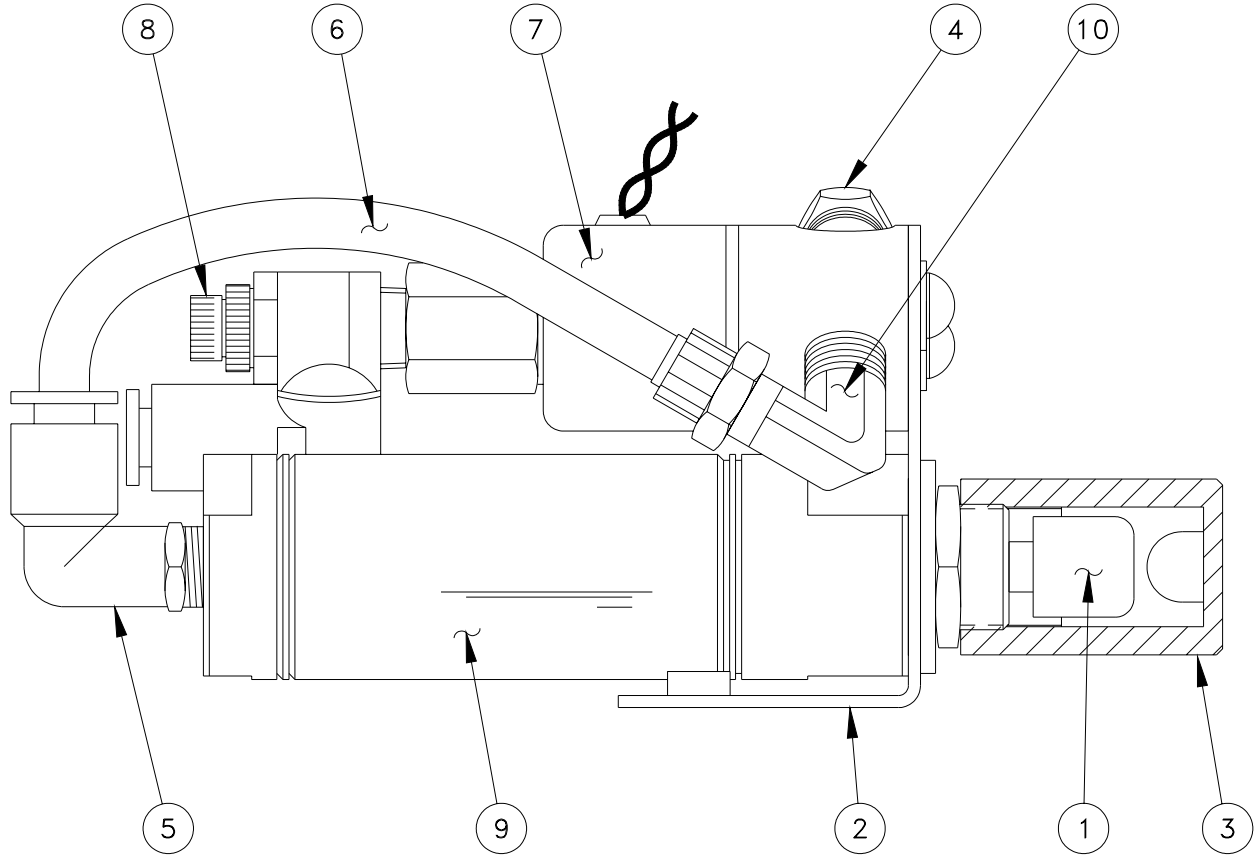

Item No.	Description	Part No.	Qty	Item No.	Description	Part No.	Qty
1	Plunger, Pinch	MB1050-2	1	6	Tube, .250 x .040	ST4012	4.5"
2	Bracket, Pinch	MB1384-1	1	7	Valve, Sol, 115V [2]	ST6003-1	1
3	Tube, Pinch	MB1282	1	8	Valve, FC w/Elbow	ST6231	1
4	Vent, Breather	ST4003	2	9	Cylinder, 1 1/8	ST6081	1
5	Elbow, 1/4T x 1/8P	ST4144	1	10	Ell, Male 1/4T x 1/8P	ST4010	1

[1] MB1300-5 is 115V, MB1300-6 is 230V.

[2] For 230V, Use Valve ST6003-5.

FIGURE 11: P/N MB1403-1 CUTTING SPEED REGULATOR

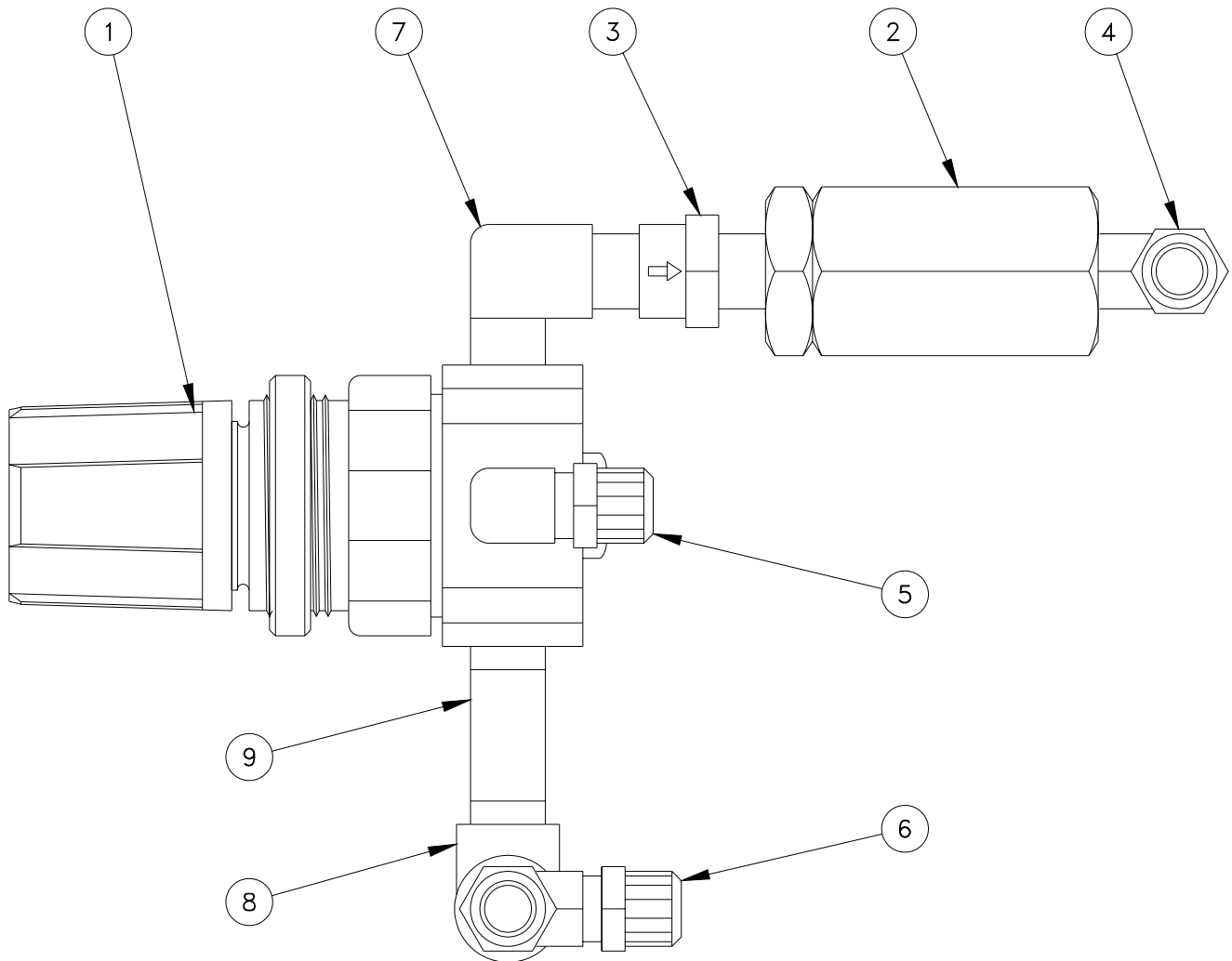

Item No.	Description	Part No.	Qty	Item No.	Description	Part No.	Qty
1	Pressure Regulator [1]	MB1376-1	1	6	Tee, 1/4T x 1/8P	ST4011	2
2	Abrasive Filter	MB1319	1	7	El, Stree, 1/4P	ST4004	1
3	Check Valve	ST6022	1	8	Tee, 1/4P, Brs	ST4036	1
4	Tee, Male 1/4T [2]	ST4018	1	9	Nipple, 1/4P x1.25	ST4050	1
5	Elbow, 1/4T x 1/8P	ST4010	1				

[1] For MicroBlaster Serial No. 0 - 8499, use Air Pressure Regulator MB1320-1.

[2] For MicroBlaster Serial No. 0 - 8499, use Connector ST4006.

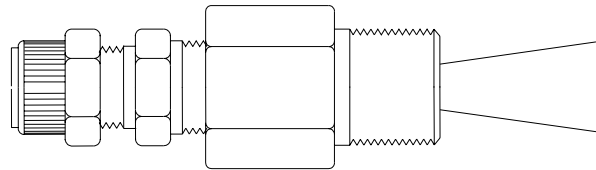
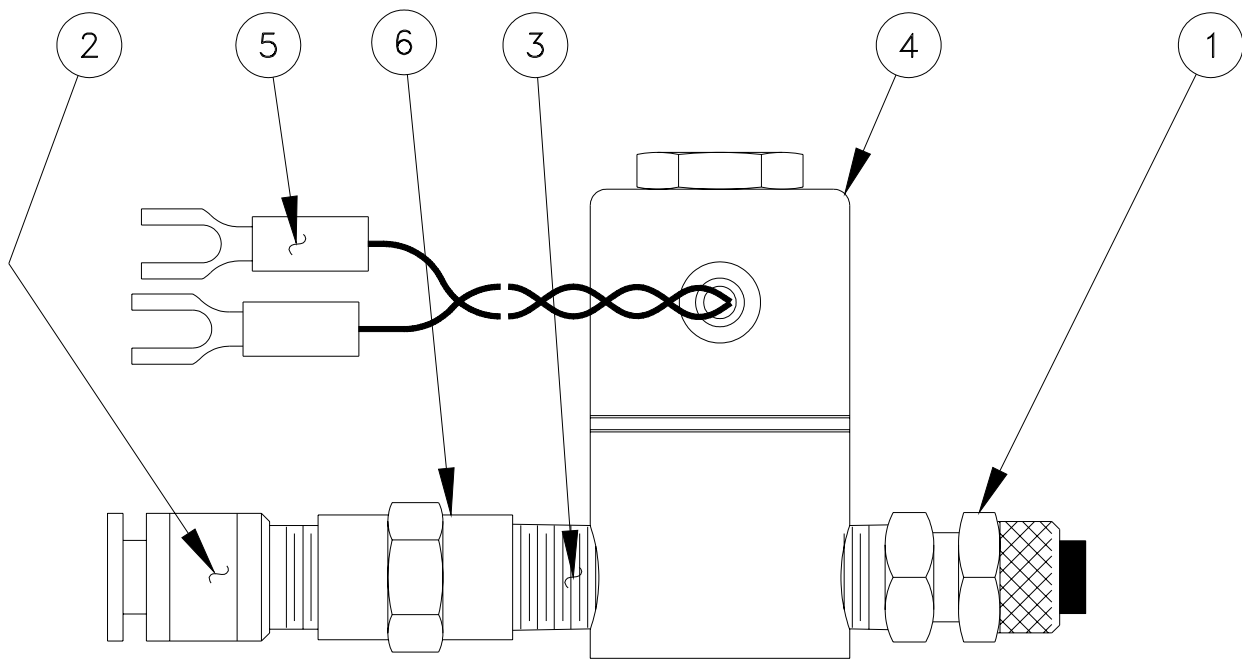
FIGURE 12A: P/N MB1170 BLEED VALVE ASSEMBLY**FIGURE 12B: P/N MB1198-9^[1] (-10) AIR VALVE ASSEMBLY**

Item No.	Description	Part No.	Qty
1	Conn. Male, 1/4T x 1/8P	ST4006	1
2	Conn. Male, 1/4T x 1/8P	ST4166	1
3	Nipple, Close, .125	ST4049	1
4	Valve, Sol, 115V [2]	ST6013-1	1
5	Term. Fork, Crimp	ST7010-1	2
6	Coupling, .125P	ST4029	1

[1] MB1198-9 is 115V, MB1198-10 is 230V.

[2] For 230V, use valve ST6013-5.

Rev. 10/02

**FIGURE 13: P/N MB1456-1 TANK EXTENDER KIT [1]
(Optional)**

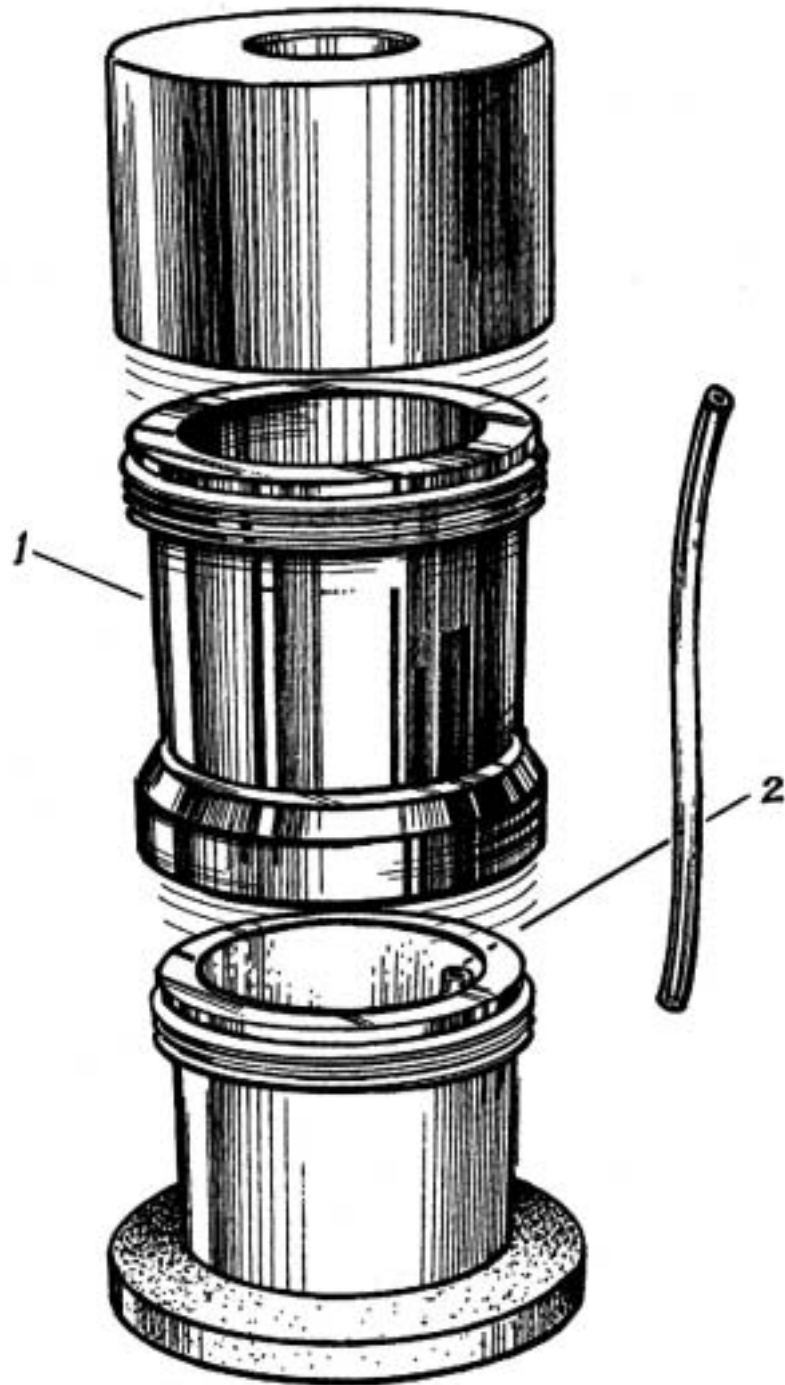

Item No.	Description	Part No.
1	Tank, Extender 5" [2]	MB1090-1
2	Bypass Tube 10"	[3]

[1] 5" Tank Extender Kit is shown, 10" Tank Extender Kit is P/N MB1456-2.

[2] 10" Tank Extender is P/N MB1090-2.

[3] Bypass Tube is part of Tank Extender Assembly.

**FIGURE 14: P/N MB1237-3 ABRASIVE DIVIDER ASSEMBLY
(Optional)**

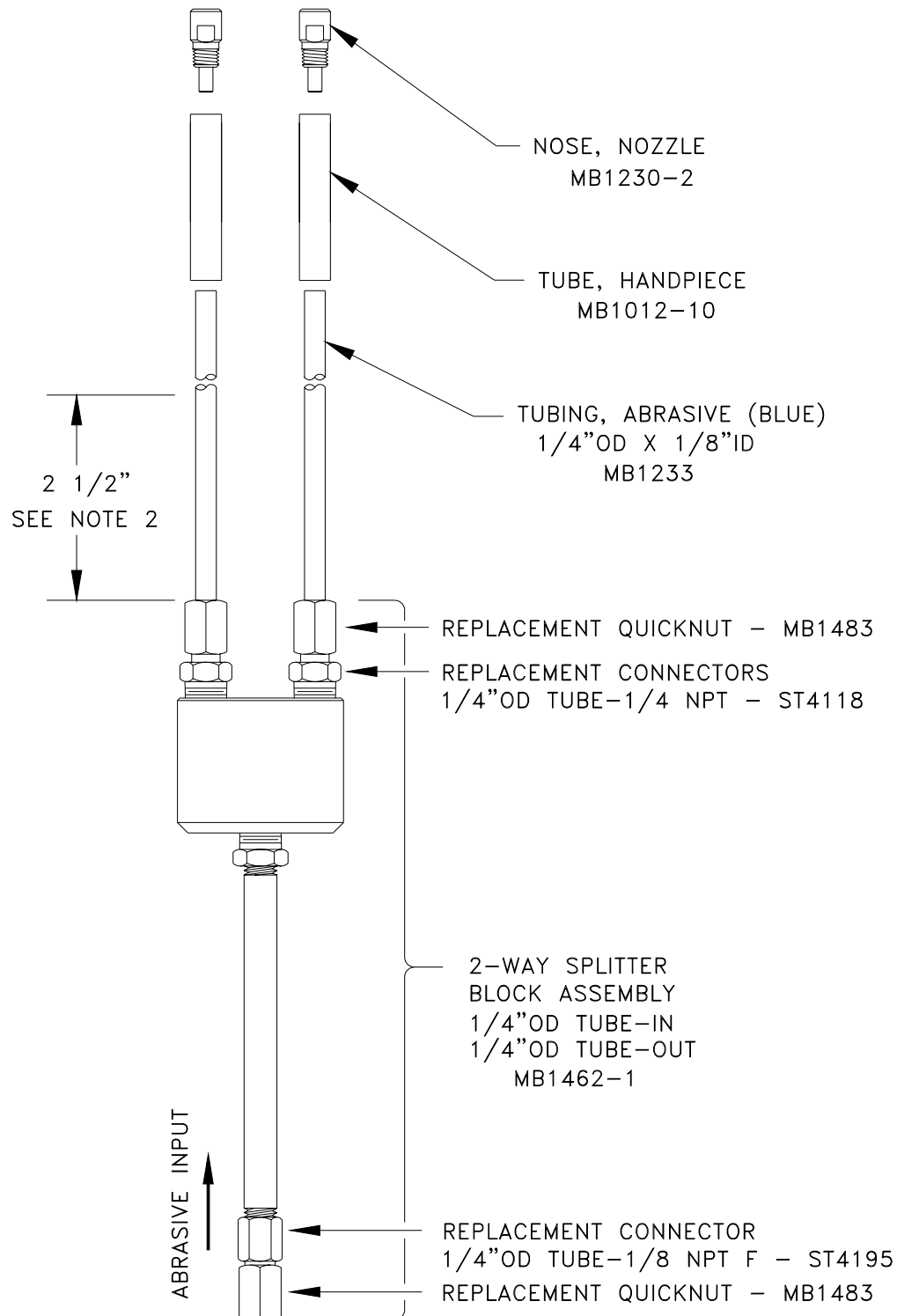

Installation Notes:

- 1) Install the splitter vertically with the two output hoses pointing up as shown.
- 2) The output hoses must be kept straight at the exit block for a minimum of 2.5 inches and should be cut to equal lengths.
- 3) Connect the input end of the splitter (pipe) to the abrasive hose from the MicroBlaster.

Rev. 10/02

Appendix C

WorkStations

Comco, Inc. WorkStations WS2200 and WS6000

Operation and Service

The Comco WS2200 and WS6000 series WorkStations are designed for use with the Comco MB1000 series MicroBlasters. Each WorkStation provides a generous working chamber lighted by two fluorescent tubes. The work chamber has a large tempered glass viewing window with a hinge to allow access. Five inch arm holes with flexible rubber iris baffles permit access so that an operator may hold work with one hand and a nozzle handpiece with the other. The WorkStation has a 4" dust exhaust connection at the rear so that a high capacity dust collection system may be used to keep the abrasive dust completely controlled.

The Comco WorkStations WS2200 and WS6000 are designed to work as a part of a micro-abrasive blasting system consisting of the following:

1. The WorkStation
2. A dust collection system
3. A micro-abrasive blasting machine (MicroBlaster, PowerFlo, or DirectFlo)
4. Pressurized air (gas) with an air filter-dryer

Refer to Section 2 for complete system set-up instructions.

Safety Precautions

The following safety precautions are essential for safe use of the WorkStation:

1. The WorkStation operates using high voltage electrical power. The WorkStation has been designed to be safe to operate when used properly. Any device that requires electrical power requires that certain safety precautions be observed to avoid potentially hazardous situations.
 - Verify the proper operating voltage on the WorkStation by checking the nameplate located on the back of the unit.
 - Unplug the unit from facility power any time the back panel will be removed, when replacing lamps, or working near the lamp brackets.
 - Keep the interior of the WorkStation clean of dust, powder, and any foreign object or substance that could conduct electricity.
2. The Comco WorkStation is typically used as part of an abrasive blasting operation. A dust collector **must** be used in conjunction with the WorkStation.
 - Flammable powders, such as wheat starch, walnut shell and plastic, may pose a fire or explosion hazard. **Always** use a vigorous dust extraction device to prevent hanging dust clouds and minimize the risk of sparks from static electricity.
 - Gloves may be necessary for operators who are sensitive to powders or dust on their skin.
 - Some powders, if allowed to collect inside the machine, may cause electrical shorts.

WORKSTATION SET-UP AND OPERATION

Installation

1. Remove the WorkStation from its shipping container and place it securely on a solid workbench or counter so that the unit cannot tilt or fall over. Make sure that the location where it is to be used within reach of a power outlet.

CAUTION: The WorkStation weighs approximately 45 to 55 pounds, depending upon which model you purchased. Use appropriate caution while lifting.

2. Place the MicroBlaster on or near the WorkStation according to the instructions in the machine's manual.
3. Identify the abrasive tubing leading from the vent pinch on the rear (or side) of the MicroBlaster (see machine manual). Push the hose (hoses) into one of the small grommeted holes on the rear of the WorkStation. By putting a hand through the WorkStation 4" duct, you may pull several inches of the tube into the rear of the WorkStation so that it makes a bend in the tube, thus securing the free end of the hose.

CAUTION: The free end of the vent hose may fall out of the WorkStation and potentially whip around if left unsecured. **Always** secure the free end of the hose (see step 3 above).

Installation (cont'd)

4. Using a 4" diameter flexible duct and 2 hose clamps (usually with the dust collector) connect the WorkStation to a dust collection system.
5. Follow the instructions in your MicroBlaster manual to prepare for blasting.

CAUTION: The air that comes out of the nozzle contains abrasive. Do not point the nozzle at anything that could be harmed or damaged as a result of abrasive flow.

6. With the Power switch turned OFF, connect the power cord to the AC voltage outlet.
7. Turn the Power switch on the rear of the WorkStation to the ON position. The Lamps in the WorkStation should light.

Operation

8. Micro-abrasive blasting operations should be conducted according to the instructions in the MicroBlaster's operation manual.

CAUTION: Never point the nozzle in the direction of the glass window because this will etch the glass and cause unnecessary expense for a replacement part.

9. Turn the Power OFF when the WorkStation is not in use.

Common Problems, Causes and Solutions**Light won't light**

- | | | |
|---|--|---|
| • | Fluorescent lamps burnt out | Replace lamps (commercial items) |
| • | Powder in electrical contacts. Powder can build up in lamp bracket and prevent electrical contact. | <ol style="list-style-type: none"> 1. Unplug unit 2. Remove lamps 3. Use brush to clean out bracket 4. Reinstall Lamps 5. Plug in unit and test |
| • | Ballast failed | <ol style="list-style-type: none"> 1. Remove Lamps 2. Turn Power switch to ON 3. Using voltmeter, test for voltage across lamp bracket terminals <p>CAUTION: Practice electrical safety to prevent shock.</p> |
| • | Switch failed | <ol style="list-style-type: none"> 1. Unplug unit. 2. Remove back panel 3. Using ohmmeter, test for continuity across switch terminals with the switch set to on. |

Dust builds up inside

Service Dust Collector

The 'CLASSIC' WORKSTATION - WS2200

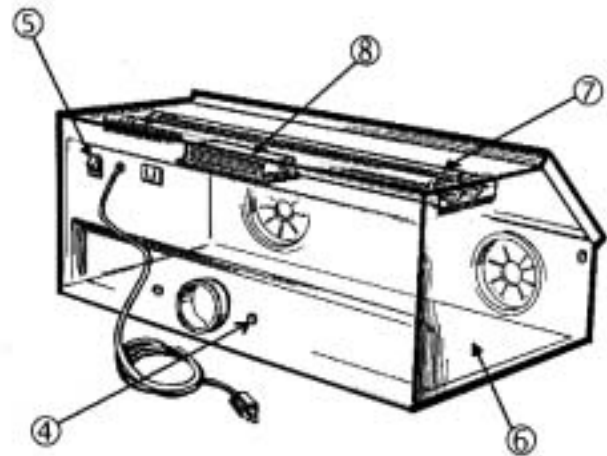
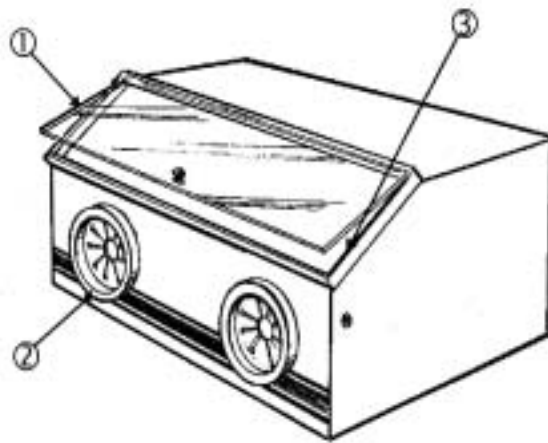

ITEM	Description	WS2200	WS6000	ITEM	Description	WS2200	WS6000
1	Window	WS2014-2	WS6014	5	Switch	ST7003	ST7977
2	Iris, 5"	WS6006*	WS6006	6	Mat	WS1136	WS6007
3	Seal	ST3260	ST3366	7	Lamp	F15T8	F14T12
4	Grommet	ST5010	ST5010	8	Ballast**	ST7693	ST7693-2

* Older WorkStations (S/N below 4460) use 4" Iris P/N WS2028-1

** 115 Volt only, 230 Volt models use ST7239 (WS2200), and ST7693-3 (WS6000)

CLEARVIEW WORKSTATION - WS6000

